

Classification Cancelled
Auth: CG-AMC

Date: 1 FEB 49

By: John D. Bannett
Sept 1950

T.O. 5N7-2-2-1
(Formerly 05-25BB-5)

HANDBOOK OPERATION AND SERVICE INSTRUCTIONS

DAKOTA

*Quantity ordered
for new maps
AESN 24/69*

*20-47 418-59
10-24 10-23
10-23 408-36
394 13-95
41*

TYPE B-3 DRIFT METER NAVY STOCK NOS.

R88-S-872-27, -40, -48, -51, -53, -60, -68

(ECLIPSE-PIONEER)

REVISION NOTICE

**LATEST REVISED PAGES SUPERSEDE
THE SAME PAGES OF PREVIOUS DATE**

Insert revised pages into basic
publication. Destroy superseded pages.

BASIC AND ALL CHANGES HAVE BEEN MERGED TO MAKE THIS
A COMPLETE PUBLICATION

PUBLISHED UNDER AUTHORITY OF THE SECRETARY OF THE AIR FORCE
AND THE CHIEF OF THE BUREAU OF AERONAUTICS

*27-90
13-95*

AF Olmsted May 65, 200 REPRINT

15 MARCH 1946
REVISED 1 SEPTEMBER 1950

SECTION I INTRODUCTION

1. This Handbook is issued as the general basic instructions for the equipment involved.
2. This Handbook contains instructions for the installation, Operation, and Maintenance of the Gyro Stabilized Drift Meter, manufactured by the Eclipse-Pioneer Division of Bendix Aviation Corporation, Teterboro, New Jersey.

TABLE I

COMPARATIVE TABLE OF TYPE IDENTIFICATIONS FOR GYRO STABILIZED DRIFT METERS			
<i>Army Type</i>	<i>Navy Stock No.</i>	<i>AN Type</i>	<i>Pioneer Type</i>
B-3	R88-S-872-27		2902-2A-A
B-3	R88-S-872-27		2902-2A-B
B-3	R88-S-872-27		2902-2A-C
B-3			2910-2A-A
B-3			2910-2A-B
B-3	R88-S-872-27		2913-2A-A
B-3	R88-S-872-27		2913-2A-B
B-3	R88-S-872-27		2914-2A-A
B-3	R88-S-872-27		2914-2A-B
B-3	R88-S-872-27		2914-2A-C
B-3	R88-S-872-40		2915-2A-A
B-3	R88-S-872-40		2915-2A-B
B-3	R88-S-872-40		2916-2A-A
B-3	R88-S-872-40		2916-2A-B
B-3	R88-S-872-40		2916-2A-C
B-3	R88-S-872-53		2917-2A-B
B-3	R88-S-872-51		2919-2A-A
B-3	R88-S-872-51		2919-2A-B
B-3			2921-2A-A
B-3			2922-2A-A
B-3			2923-2A-A
B-3		AN5763-27	2924-2A-A
B-3		AN5763-51	2926-2A-A
B-3		AN5763-60	2928-2A-A
B-3	R88-S-872-68	AN5763-68	2929-2A-A
	R88-S-872-27		2934-2D-A
	R88-S-872-53		2935-2D-A
	R88-S-872-53	AN5763-53	2936-2D-A
B-3	R88-S-872-40	AN5763-40	2938-2E-A
B-3		AN5763-51	2939-2E-A
	R88-S-872-53	AN5763-53	2940-2E-A
B-3	R88-S-872-60	AN5763-60	2941-2E-A
	R88-S-872-27	AN5763-27	2944-2E-A
B-3		AN5763-60	2948-2E-A
	R88-S-872-27	AN5763-27	2949-2E-A-27
B-3		AN5763-33	2949-2E-A-33
	R88-S-872-48	AN5763-48	2949-2E-A-48
	R88-S-872-53	AN5763-53	2949-2E-A-53

SECTION II DESCRIPTION

1. GENERAL.

(See figures 1 through 3.)

- a. The gyro stabilized drift meter is an optical instrument used in aircraft navigation for determination drift, azimuth of a fixed ground object, and data from which ground speed and wind velocity may be computed.

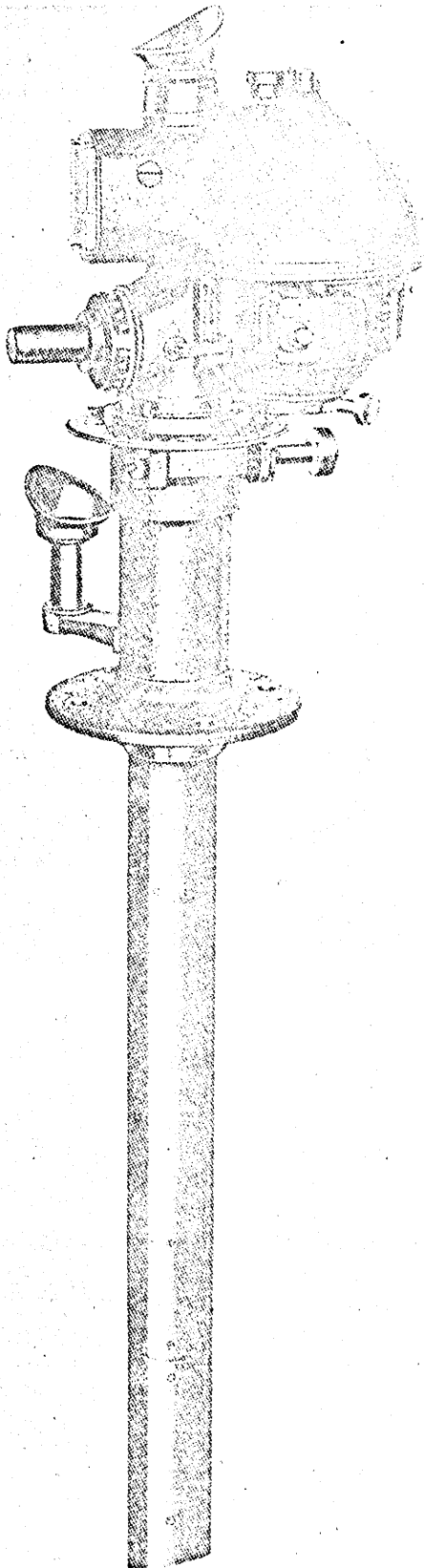

Figure 3—Gyro Stabilized Drift Meter with Starting Transformer (Pioneer Types 2924-2A-A, 2926-2A-A, 2928-2A-A, 2929-2A-A, 2936-2D-A, 2938-2E-A, 2939-2E-A, 2940-2E-A, 2941-2E-A, 2944-2E-A, 2948-2E-A, 2949-2E-A-27, 2949-2E-A-33, 2949-2E-A-48, 2949-2E-A-53)

b. The drift meter is mounted vertically in the aircraft by means of a fixed mounting housing. It consists of a telescope tube, with objective and projecting beneath the fuselage, and an electrically-driven gyro encased in a housing at the eyepiece end of the instrument.

c. The telescope tube contains the optical system of lenses and prisms through which ground objects beneath the airplane are viewed. The gyroscope is used to maintain the grid-lined reticle of the instrument in a horizontal position, so that when the grid lines and the sighted object are viewed simultaneously, no error is introduced as a result of roll and pitch motions of the airplane.

d. The gyro stabilized drift meter, including gyro-stabilized reticle and eyepiece, is free to rotate in its stationary housing for the measurement of drift or azimuth, indicated on the respective scales on this housing. An additional scale is attached for measuring angles of the line of sight from below the airplane for ground-speed computation data. The control handle for this scale is located opposite the housing which holds the gyroscope. This handle operates a pulley mechanism attached to a rotatable index prism in the extreme lower end of the tube.

e. The inverter converts the aircraft d-c power supply into 110 volts, 400 cycles required to operate the electric gyroscope. The inverter is mounted close to the aircraft power supply which is connected to the input electrical receptacle of the inverter. The a-c output receptacle of the inverter is connected to the drift meter gyro by means of a shielded, insulated, two-wire cable.

2. DETAILED.

(See figures 4 through 9.)

a. GENERAL.

(1) Drift meters covered by this Handbook are basically similar in construction and operation and perform the same functions when in use. The instrument has been designed so that the length of the telescopic tube extending beneath the fuselage can be varied to accommodate different installations.

(2) The following changes have been introduced since the production of Pioneer type 2902-2A-A: the tapered centers in the line-of-sight mechanism in early models have been replaced by a ball bearing and shaft; a redesigned azimuth drive has been substituted for the drive in early models which employed a thrust shaft to disengage the drive worm; the early Pioneer type AN-3 gyro system was replaced in turn by the Pioneer types AN-5 and AN-7 gyros, with the Pioneer type AN-20 gyro installed in the current production units.

(3) In the case of early models, the 110-volt, 400-cycle, a-c power unit required for operation of the gyro motor was supplied with the instrument. This was either the Pioneer inverter or the Eclipse converter. Drift meters with numbers following Pioneer type 2915-2A-B were not furnished with the a-c power unit.

(4) To enable the gyro to start and gain speed when the aircraft is flying at extremely low temperatures, type AN5763 drift meters are equipped with a starting transformer. The transformer is mounted on the lower gyro housing and supplies 220-volt power momentarily until the gyro gains speed.

(5) For a detailed list of variations in design and tube length and the accompanying type-number designations, refer to table II.

(6) Since the Pioneer drift meter type number indicates variations in design, in addition to tube length, the original type number cannot be changed on those instruments whose length has been modified. Therefore, at time of modification or reinspection, any instrument whose length is not as listed for the corresponding type number in table II will have a new type number assigned. This new number will consist of the original type number plus a dash number to indicate the new length, as measured from the bottom of the mounting flange (stationary housing) to the tip of the head assembly. For example, if the tube length of drift meter type 2914-2A-C has been changed from its original 27 inches to 20 inches, the name plate will now be marked 2914-2A-C-20, in the space directly above "METER, DRIFT."

b. TYPE B-3 (PIONEER TYPES 2902-2A-A, 2902-2A-B, 2910-2A-A, 2910-2A-B, 2913-2A-A, and 2915-2A-A).

(1) UPPER GYRO HOUSING (13, figure 4).

—The upper gyro housing, the lower gyro housing, and the filter housing comprise the upper framework of the instrument. Installed on the inside of the upper gyro housing are the lenses and prisms which transmit the reticle image through the beam-splitting cube for super-imposition on the ground-object image; together with the electrical wiring required for illumination of the reticle. The one-power eyepiece assembly, the eyepiece holder, and the rheostat knob are located on the top of the upper gyro housing.

(2) 1X EYEPIECE ASSEMBLY (9, figure 4).

—Ground objects are sighted through the drift meter at the one-power eyepiece lens assembly which consists of four lens elements secured in the eyepiece housing by a retainer ring and lock nut. The eyepiece is provided with an eyepiece buffer and a soft rubber eye guard. The lens housing threads into the eyepiece holder assembly on the upper gyro housing.

(3) OCULAR HOUSING HOLDER (8, figure 4).—The eyepiece is focused for sharp and clear images by adjusting the ocular housing holder on the upper gyro housing. When the eyepiece holder is adjusted, a bronze sleeve secured in the holder turns in another bronze sleeve fitted into the collar on the upper gyro housing.

(4) THREE-VOLT LAMP ASSEMBLY (11, figure 4).—This assembly is screwed through the hole in the apex of the upper gyro housing into a socket as-

assembly, and provides illumination for the grid-lined reticle. The assembly consists of a three-volt lamp, a washer, and the lamp base. A setscrew in the step at the apex of the upper gyro housing prevents the assembly from slipping out, and properly positions the lamp for uniform illumination of the reticle.

(5) RHEOSTAT AND KNOB (10, figure 4).— To vary the intensity of illumination over the reticle, an 18-ohm resistant rheostat is connected in series with the lamp assembly. The shaft of the rheostat protrude through a hole in the upper gyro housing, and the rheostat knob is secured to the shaft. Eight differ-

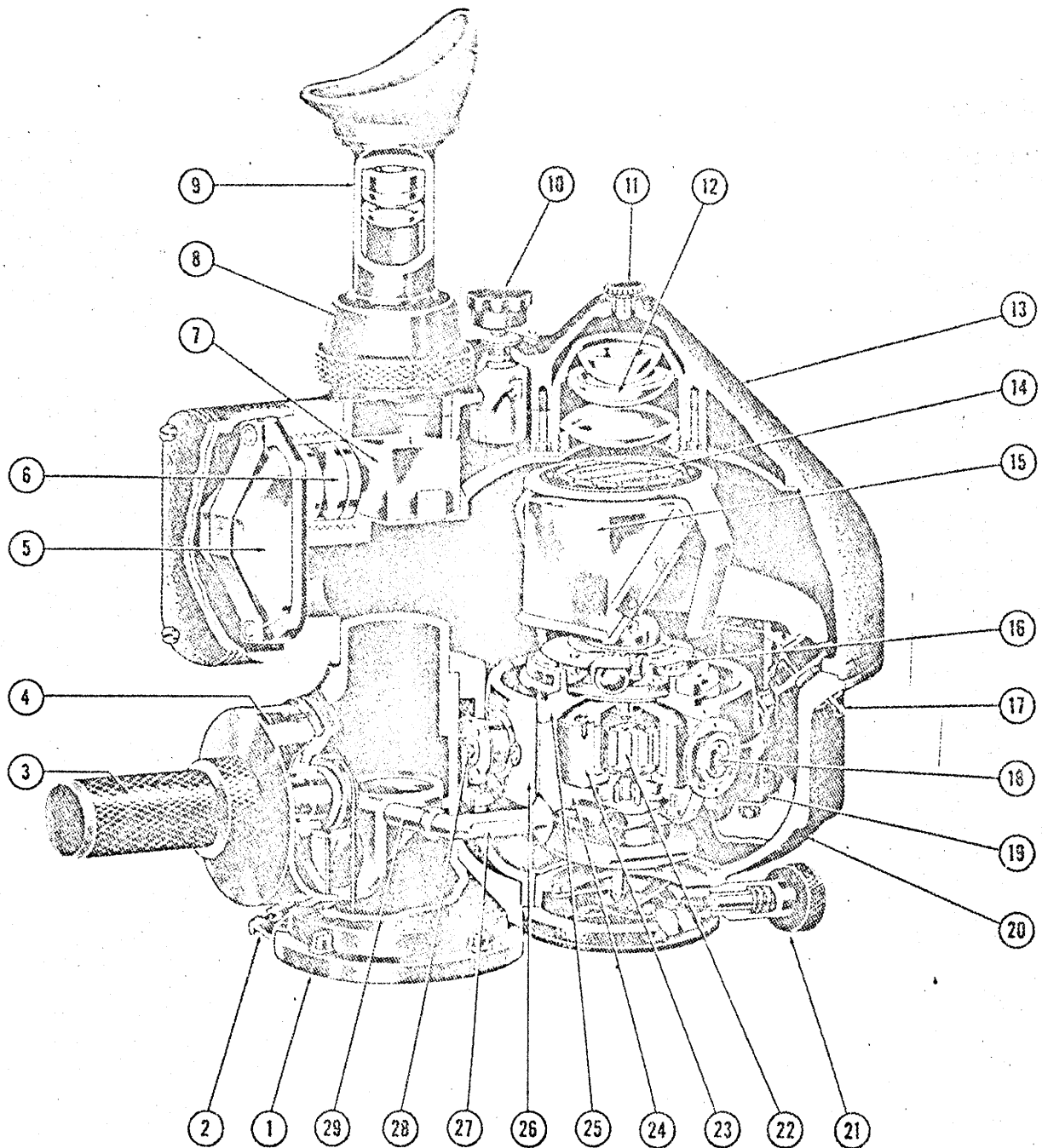

- | | | | |
|---|-----------------------------|-----------------------------|----------------------|
| 1 Filter housing | 8 Ocular housing holder | 15 Gyro prism | 22 Stator assembly |
| 2 Index pointer | 9 1X eyepiece assembly | 16 Erection system assembly | 23 Rotor assembly |
| 3 Line-of-sight control handle | 10 Rheostat knob | 17 Gyro switch | 24 Gyro frame |
| 4 Line-of-sight dial | 11 Three-volt lamp assembly | 18 Gyro pivot | 25 Gyro frame cap |
| 5 Reticle lens reflector prism assembly | 12 Condenser lens assembly | 19 Socket | 26 Gimbal ring |
| 6 Gyro lens assembly | 13 Upper gyro housing | 20 Lower gyro housing | 27 Filter handle |
| 7 Cube and pad assembly | 14 Reticle | 21 Caging knob | 28 Gimbal ring pivot |
| | | | 29 Filter assembly |

Figure 4—Three-Quarter Cutaway View—Eyepiece End—Army Type B-3 Drift Meter (Pioneer Types 2902-2-A, 2902-2A-B, 2910-2A-A, 2910-2A-B, 2913-2A-A, and 2915-2A-A)

ent degrees of brightness between the disconnect and the maximum-intensity positions can be obtained by turning the rheostat knob. Two stop studs, screwed into the upper gyro housing, limit the travel of the knob pointer. When the knob is turned clockwise and its pointer strikes the stud, maximum light intensity results. When the knob is turned counterclockwise and the pointer strikes the other stud, the lamp goes out.

(6) CUBE AND PAD ASSEMBLY (7, figure 4).—Two crown-glass prisms of specific refraction characteristics are cemented together to form a beam-splitting cube. The cube rests in the upper gyro housing on two metal pads secured to the cube sides. Adjusting screws and setscrews in each side of the upper gyro housing are used for proper positioning of the cube in final collimation of the instrument.

(7) RETICLE LENS REFLECTOR PRISM ASSEMBLY (5, figure 4).—This assembly is secured in the upper gyro housing through the name plate opening of the housing. It consists of a 30-degree reflecting prism secured in a prism holder by a prism clamp and two screws. When centering the reticle image, the prism is adjusted on the horizontal or vertical axis by use of the four screws that secure this assembly in the housing.

(8) GYRO LENS ASSEMBLY (6, figure 4).—This assembly contains two lens elements separated by a spacer and secured in a lens housing. The housing is screwed into the threaded hole provided for it inside the upper gyro housing and is finally located between the 30-degree reflector prism and the beam-splitting cube. A large setscrew, with setscrew cushion attached, covers the hole in the side of the upper gyro housing through which the position of the gyro lens can be adjusted.

(9) CONDENSER LENS ASSEMBLY (12, figure 4).—This assembly provides uniformly-centered illumination over the reticle. There are three lens elements in the lens housing secured in place with two separate lens mountings. In early models, a red cellophane filter was used between two of these lens elements but this material should be eliminated upon overhaul and the photographic reticle that is now used must be installed in the drift meter. The condenser lens assembly is secured with four screws to four bosses on the upper gyro housing directly beneath the socket and lamp assemblies.

(10) RETICLE (14, figure 4).—The reticle is a ground-glass viewing element that has a horizontal, heavy photographic grid line across the center of the reticle and broken at the center; a vertical center line, broken at the center; and two ground speed lines that parallel the vertical center line. There are four, light photographic grid lines and four, heavy grid lines, both above and below the broken horizontal center line. The reticle is mounted in a reticle support which is secured with screws to the gyro cap of the gyro assembly.

(11) GYRO PRISM AND SUPPORT (15, figure 4).—The gyro crown-glass prism is located be-

tween the reticle glass and the gyro. The prism in its holder is secured to a bracket-like support which fits on two dowel pins pressed into the lower gyro housing.

(12) FILTER HOUSING (1, figure 4).—The filter and pulley assembly, which contains the line-of-sight mechanism and the two filters, is secured in the filter housing. The bottom flange of the filter housing is fastened to the top flange of the adapter of the rotating tube assembly. The filter housing is matched and fitted to the upper and lower gyro housings and cannot be interchanged with a filter housing of any other drift meter.

(13) LOWER GYRO HOUSING (20, figure 4).—The complete gyro assembly is installed in the lower gyro housing. The housing is matched to the filter housing and to the upper gyro housing and secured to each by screws.

(14) GYRO SWITCH (17, figure 4).—The gyro toggle switch is mounted on the lower gyro housing underneath the narrow flange at the top of the housing and is secured with a large hex nut. Two leads are soldered to the switch terminals.

(15) ELECTRICAL CONNECTION. — The 110-volt, 400-cycle power which operates the gyro motor enters the instrument at the electrical connector receptacle.

(a) On types 2902-2A-A and 2910-2A-A, the connection is made by means of a fitting which screws into the bottom of the lower gyro housing. A coupling nut holds the fitting on the cable assembly. At the other end of the cable, an electrical connector plug, soldered to the ferrule, connects the drift meter to the inverter.

(b) On types 2902-2A-B, 2910-2A-B, 2913-2A-A, and 2915-2A-A, power connection to the gyro is made through a Breeze two-pin receptacle. The receptacle is secured to the lower gyro housing by means of four screws.

(16) GYRO ASSEMBLY. (See figure 4).—The Pioneer type AN-3 gyro consists of the following parts and assemblies:

(a) ERECTION SYSTEM (16).—The erection system consists of a top plate and a bottom ring separated by three posts and secured to each other by screws. Gear wheels fitted on pivot staffs are secured in jewels between the top plate and the bottom ring. The erection system is mounted in the track cut in the gyro frame cap, and the wheels turn on the sides of the track.

(b) STEEL BALL.—The steel ball rides in the track within the limits set for it by the roller and the ball retainer bracket of the erection system.

(c) DRAG CUP.—The drag cup, in which the magnet rotates, is fastened to the top plate of the erection system by means of screws.

(d) GIMBAL RING (26).—The gimbal ring, an aluminum casting, enables the gyro rotor to rotate in the lower gyro housing. The gimbal ring is held in supports in the housing by two pivots which turn in ball bearings.

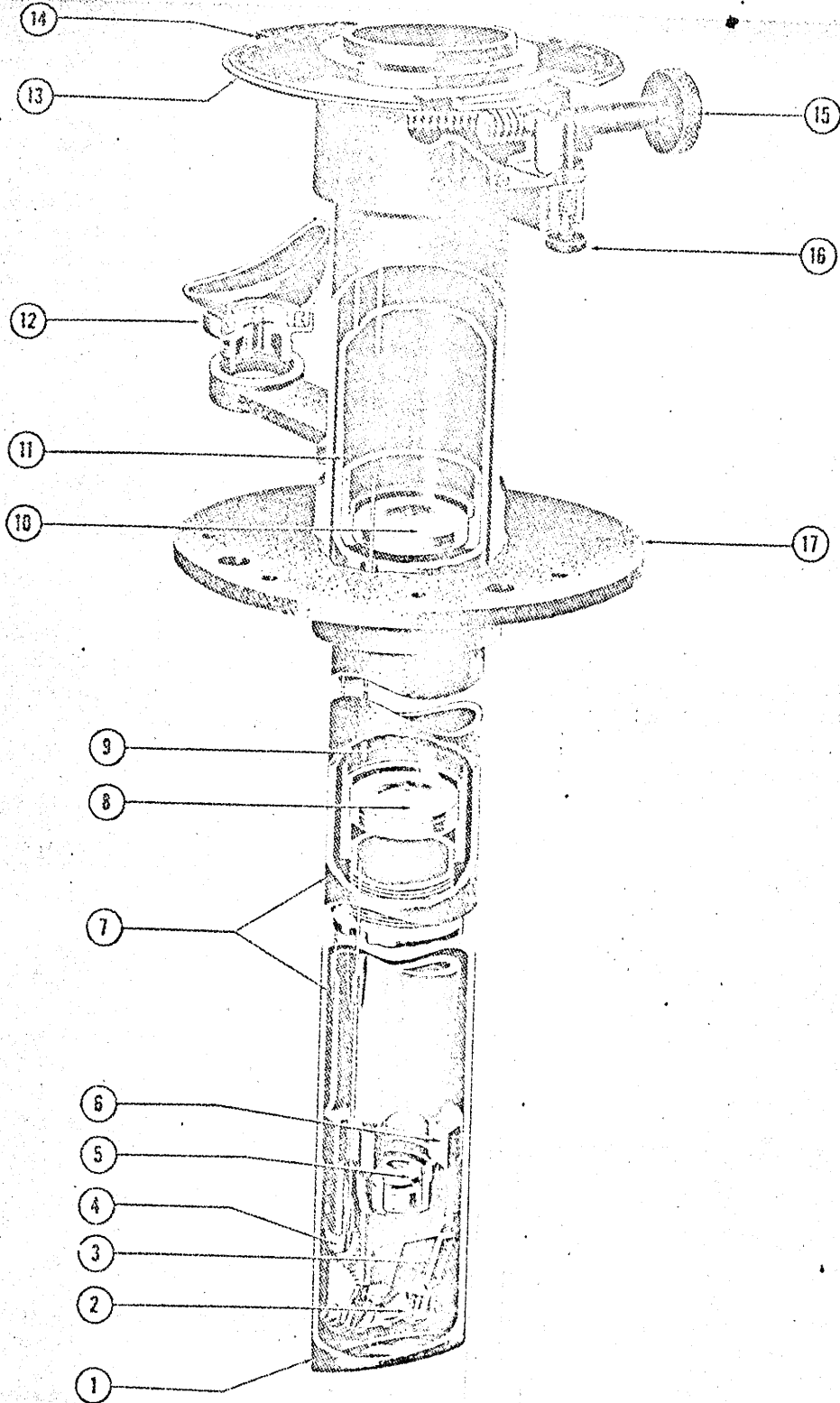

- 1 Head assembly
- 2 Index prism
- 3 Reflecting prism holder assembly
- 4 Large pulley

- 5 Eyepiece and objective lens
- 6 Main bracket
- 7 Outer sleeve
- 8 Lower achromat lens

- 9 Index prism adjusting rod
- 10 Upper achromat lens
- 11 Rotating tube assembly
- 12 3X eyepiece assembly

- 13 Azimuth dial
- 14 Drift scale
- 15 Tangent screw knob
- 16 Thrust shaft knob
- 17 Stationary housing

Figure 5—Three-Quarter Cutaway View—Stationary Housing and Tube End—Army Type B-3 Drift Meter (Pioneer Types 2902-2A-A, 2902-2A-B, 2902-2A-C, 2910-2A-A, 2910-2A-B, 2913-2A-A, 2913-2A-B, 2914-2A-A, 2915-2A-A, 2915-2A-B, and 2916-2A-A)

(e) GIMBAL BALANCE WEIGHT.—This weight is a shaped copper strip held on the gimbal ring by a gimbal-weight screw. To obtain static balance of the gyro, the screw can be loosened and the weight shifted to any position on the ring.

(f) MAGNET.—The magnet and magnet adapter are secured on the upper rotor shaft and revolve inside the drag cup.

(g) GYRO FRAME CAP (25).—The steel gyro frame cap is secured to the top rim of the gyro frame. The steel ball of the erection system rides in the track cut in the top of the gyro frame cap. The reticle support fits over the gyro frame cap and is held to the narrow edge of the cap by four screws. The gyro frame, the gyro frame cap, and the reticle support are matched parts.

(h) GYRO FRAME (24).—The stator and rotor assemblies, comprising the gyro motor, are mounted in the gyro frame.

(i) ROTOR ASSEMBLY (23).—This assembly consists of a flywheel, a lamination and resistance ring assembly, and a steel rotor shaft. The rotor shaft is spun through the flywheel which is fastened by screws to the top of the lamination and resistance ring assembly.

(j) OUTER CONTACT AND SPRING ASSEMBLY.—One outer contact and spring assembly is secured on each side of the gimbal ring, but held away from the ring by spacers and insulating bushings.

(k) STATOR ASSEMBLY (22).—The stator assembly is secured to the floor of the gyro frame by means of a stator nut. The stator consists of 64 stator laminations, a main winding, auxiliary winding coils, and 16 wedge insulations. The stator leads extend through two holes in the floor of the gyro frame, and are soldered to the bent contact and insulation assemblies on the bottom of the gyro frame.

(l) CONDENSERS.—Two condensers are balanced on the bottom of the gyro frame and secured there by means of condenser brackets. Each condenser has a capacity of 125 microfarads for operation at 180 volts, 400 cycles. Two leads of the condenser are soldered to a condenser terminal, and two leads to the bent contact and insulation assembly on the bottom of the gyro frame.

(m) CUP AND BALL ASSEMBLY.—This assembly consists of a ball bearing and an outer race. One assembly is pressed into the gyro frame cap and the other into the floor of the gyro frame. Bearing cones on the upper and lower rotor shaft turn in the cup and ball assemblies as the rotor revolves.

(n) RETICLE COUNTERWEIGHT.—The weight of the reticle support and the reticle glass on the gyro is balanced by a counterweight rotatable about the bottom of the gyro frame. The counterweight is held on the bottom of the gyro frame by two screws which can be loosened to turn the weight. A counterweight balancing ring is fastened on the reticle counterweight.

(o) CAGING KNOB (21).—A spring-restrained caging knob locks and unlocks the diaphragm leaves of the caging device, which is located at the bottom of the lower gyro housing.

(17) FILTER ASSEMBLY (29, figure 4).—Two filters, one a clear glass and the other a shade glass, are held in a support which is secured to a shaft in the filter housing.

(18) FILTER HANDLE (27, figure 4).—The handle at the side of the filter housing marked "SHADE GLASS" is fitted to the filter shaft. When the handle is turned in the direction of the arrow, "IN," the shade-glass filter is thrown into the optical field.

(19) LINE-OF-SIGHT CONTROL HANDLE (3, figure 4).—The control handle is fastened to a tapered blank which rotates in the filter housing as the handle is turned. A pulley is lapped to the blank and turns with the handle. A handle cap is screwed on to the control handle.

(20) LINE-OF-SIGHT DIAL (4, figure 4).—The line-of-sight dial rotates on the filter housing with the control handle. The dial is graduated in 1-degree increments over a range from 16 degrees forward to 87 degrees rearward of the vertical. Detents on the control handle indicate a line of sight of 0, 50, and 70.9 degrees from the vertical.

(21) INDEX PRISM ADJUSTING RODS (9, figure 5).—The two connectors on the line-of-sight pulley cable are linked by two adjusting rods to the connectors on the main-bracket pulley cable in the lower end of the tube. The length of the rods varies with the tube length of the instrument in which the rods are installed.

(22) STATIONARY HOUSING (17, figure 5).—The drift meter rotates freely in the stationary housing, and the lower flange of the housing serves as a fixed mounting for installation of the instrument on the aircraft. Bronze bearings are sweated into the housing and provide smooth-turning surfaces for the rotating tube assembly. Seventy-three steel balls carefully positioned in a track cut in the bearing at the upper end of the housing increase the freedom of rotation of the instrument.

(23) TANGENT SCREW KNOB AND THRUST SHAFT KNOB (15 and 16, figure 5).—Slow-motion rotation of the drift meter in azimuth is obtained by the engagement of the azimuth drive worm and the azimuth drive gear on the rotating tube. To disengage the worm for free rotation of the instrument, the tangent screw knob is pressed in toward the tube until the thrust shaft snaps up into place. A stationary housing plate holds the azimuth worm in place on the housing.

(24) ROTATING TUBE ASSEMBLY (11, figure 5).—This assembly rotates in the stationary housing. An adapter, pressed on to the upper end of the assembly, is secured to the bottom flange of the filter

housing. The lower end of the assembly attaches to the outer sleeve. A bronze inner bearing, sweated on the tube, turns against the bronze bearing surfaces of the fixed housing. The azimuth drive gear is sweated on to the upper end of the rotating tube assembly. The steel balls placed on the stationary-housing bearing ride in the space between two flanges on the gear blank.

(25) AZIMUTH DIAL (13, figure 5).—This 360-degree scale, graduated in 1-degree increments, is positioned on dowel pins on the top flange of the stationary housing. The scale remains fixed when the instrument is rotated.

(26) DRIFT SCALE (14, figure 5).—The drift scale, fixed to the top flange of the stationary housing, indicates a measurement of drift in 1-degree increments, 20 degrees to the right and 20 degrees to the left of the zero position. The zero of the drift scale lines up with the 180-degree mark of the azimuth dial.

(27) INDEX POINTER (2, figure 4).—The index pointer is secured to the filter housing and its reference mark is set to zero on the azimuth dial. When the instrument is rotated for an azimuth sight, the pointer revolves and indicates azimuth and drift on the appropriate scales.

(28) SPARE EYEPIECE HOLDER.—When not in use, the three-power eyepiece is held in this bracket. The bracket-holder is secured to the side of the stationary housing, above the mounting flange of the housing.

(29) 3X EYEPIECE ASSEMBLY (12, figure 4).—The four elements of the three-power eyepiece lens are held in a lens housing by a retainer ring and a lock nut. The base of the housing is threaded and may be screwed into the ocular housing holder on top of the upper gyro housing. The eyepiece is equipped with an eyepiece buffer similar to the rubber guard of the one-power eyepiece assembly.

(30) UPPER ACHROMAT LENS (10, figure 5).—This two-element lens is fastened in the upper lens housing with a stop ring, and the housing is then positioned in the rotating tube assembly. The upper achromat lens is first collimated with the beam-splitting cube and the eyepiece lens before final collimation of the entire optical system.

(31) LOWER ACHROMAT LENS (8, figure 5).—The lower achromat lens is exactly similar to the upper achromat lens. This lens is held in the lower lens housing by a stop ring. The lower lens housing is part of the inner sleeve which screws into the main head bracket assembly supporting the objective lens.

(32) OUTER SLEEVE (7, figure 5).—The rotating tube assembly is connected to the lower end of the instrument by means of the outer sleeve which fits over the inner sleeve and is secured on the main bracket. Variations in tube length of the drift meter are made by changing the length of the outer sleeve and the length of the index prism adjusting rods. All instruments of the same tube length are equipped with

the same size outer sleeve.

(33) MAIN BRACKET (6, figure 5).—The main bracket, a cone-shaped aluminum casting, is positioned with its head or narrow end downward. A threaded hole in the center of the upper end of the bracket receives the inner sleeve. Two grooves are cut into the side of the main bracket to hold the index prism adjusting rods which link the line-of-sight pulley cable with the cable of the large pulley on the main bracket. Two arms extend from the head end of the main bracket, and the prism support bracket is fitted to both arms.

(34) EYEPIECE AND OBJECTIVE LENS (5, figure 5).—This lens is similar to the four-element lens in the one-power eyepiece assembly; it is fastened in a lens holder by a lock ring. An objective adapter screws into a threaded hole between the arms at the narrow end of the main bracket, and the lens holder is secured in the adapter. The lower achromat and the objective lens are first collimated together before final collimation of the entire instrument.

(35) INDEX PRISM (2, figure 5).—The rotating index prism, a crown-glass element, is secured in its holder by retainers. The holder with prism is then fastened to the index prism pivot bracket which rotates between one arm and the prism support bracket on the main bracket.

(36) REFLECTING PRISM (3, figure 5).—The stationary reflecting prism is held in its holder by retainers, and secured to the flanged face of the main-bracket arm. When the optical system has been finally collimated, a prism shutter is assembled to the back of the stationary prism holder.

(37) LARGE PULLEY (4, figure 5).—When the cable on the large pulley turns, it causes the three meshed gears positioned on the lower end of the main bracket to rotate. The small gear beneath the pulley turns the auxiliary or intermediate gear which then rotates the sector. The sector is held on the shaft-end of the index prism pivot bracket. As the sector moves, the index prism pivot bracket swings the rotating index prism.

(38) HEAD ASSEMBLY (1, figure 5).—The head assembly consists of an aluminum tube, a crown-glass index prism window, window cover, window support, and gaskets. The tube fits over the lower end of the main bracket, and the rotating index prism picks up the image of the ground object through the crown-glass window.

c. ARMY TYPE B-3 (PIONEER TYPES 2902-2A-C, 2913-2A-B, 2914-2A-A, 2915-2A-B, and 2916-2A-A).—The assemblies and parts of these instruments are similar to the corresponding assemblies and parts of the instruments mentioned in this section, paragraph 2. b., with the following exceptions:

(1) CONDENSER LENS ASSEMBLY (13, figure 6).—The integrally-tinted reticle pattern provided with instruments of this group eliminates the need for the red cellophane filter between the first two

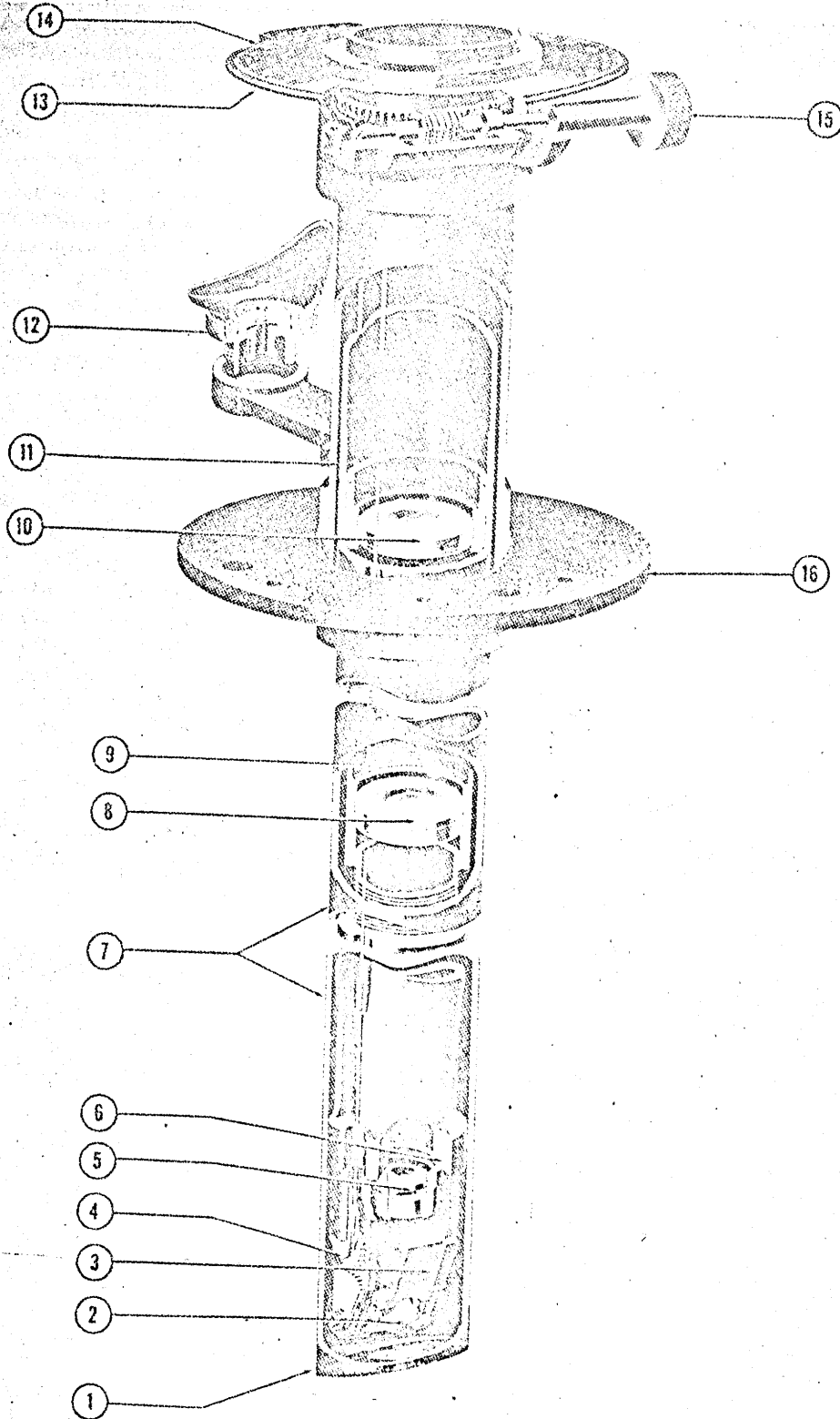

Head assembly
Index prism
Reflecting prism
Large pulley

5 Eyepiece and objective lens
6 Main bracket
7 Outer sleeve
8 Lower achromat lens

9 Index prism adjusting rod
10 Upper achromat lens
11 Rotating tube assembly
12 3X eyepiece assembly

13 Azimuth dial
14 Drift scale
15 Azimuth drive knob
16 Stationary housing.

Figure 7—Three-Quarter Cutaway View—Stationary Housing and Tube End—Pioneer Types 2914-2A-B, 2914-2A-C, 2916-2A-B, 2916-2A-C, 2917-2A-B, 2919-2A-A, 2919-2A-B, 2921-2A-A, 2922-2A-A, 2923-2A-A, 2924-2A-A, 2926-2A-A, 2928-2A-A, 2929-2A-A, 2934-2D-A, 2935-2D-A, 2936-2D-A, 2938-2E-A, 2939-2E-A, 2940-2E-A, 2941-2E-A, 2944-2E-A, 2948-2E-A, 2949-2E-A-27, 2949-2E-A-33, and 2949-2E-A-53.

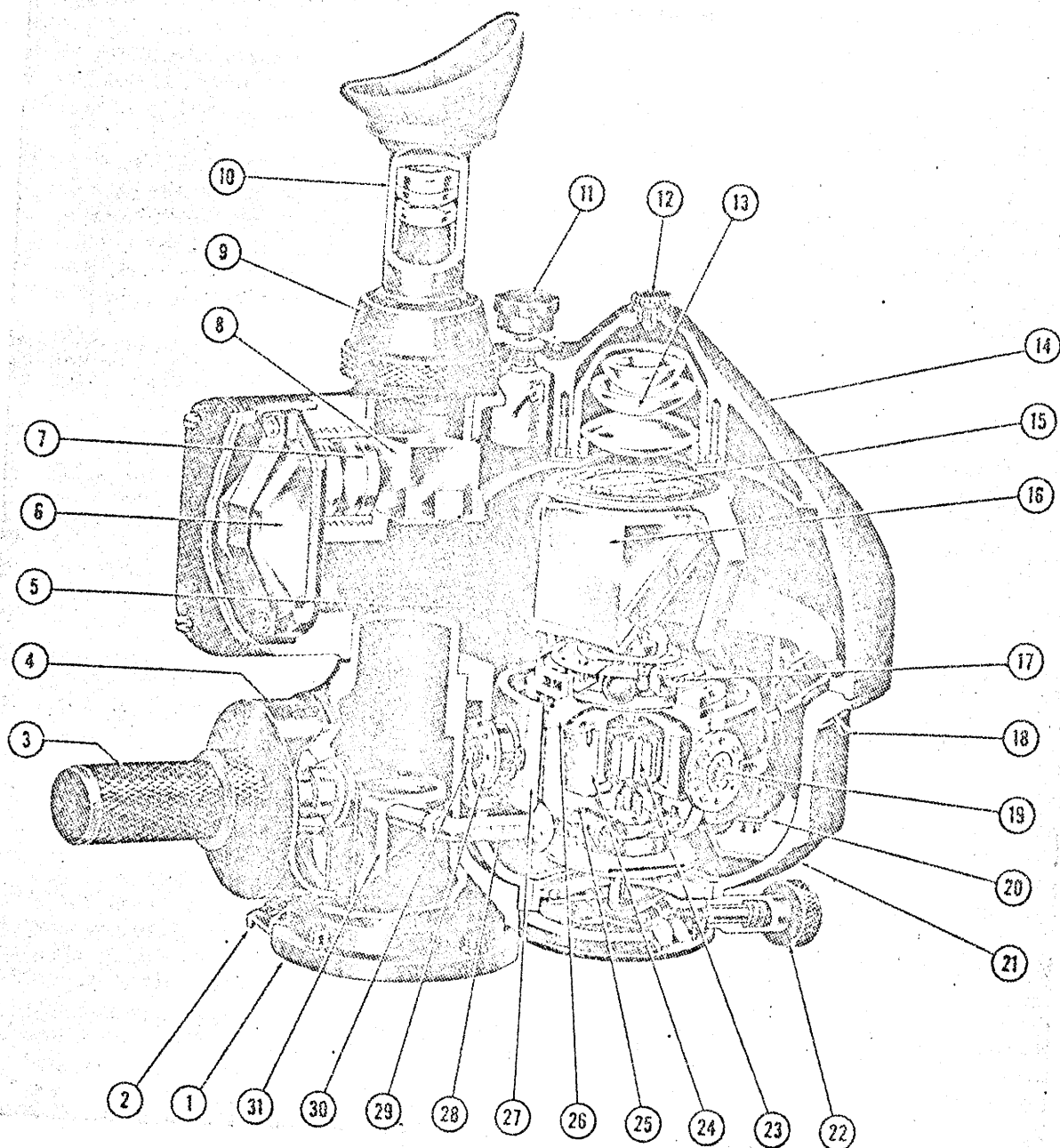

- 1 Filter housing
- 2 Index pointer
- 3 Line-of-sight control handle
- 4 Line-of-sight dial
- 5 Bracket
- 6 Reticle lens reflector prism assembly
- 7 Gyro lens assembly
- 8 Cube and pad assembly
- 9 Ocular housing holder
- 10 1X eyepiece assembly

- 11 Rheostat knob
- 12 Three-volt lamp assembly
- 13 Condenser lens assembly
- 14 Upper gyro housing
- 15 Reticle
- 16 Gyro prism
- 17 Erection system assembly
- 18 Gyro switch
- 19 Gyro pivot
- 20 Socket
- 21 Lower gyro housing

- 22 Caging knob
- 23 Stator assembly
- 24 Rotor assembly
- 25 Gyro frame
- 26 Gyro frame cap
- 27 Gimbal ring
- 28 Filter handle
- 29 Bearing retainer
- 30 Gimbal ring pivot
- 31 Filter assembly

Figure 6—Three-Quarter Cutaway View—Eyepiece End—Army Type B-3 Drift Meter (Pioneer Type 2902-2A-C, 2913-2A-B, 2914-2A-A, 2914-2A-B, 2915-2A-B, 2916-2A-A, 2916-2A-B, 2919-2A-A, and 2922-2A-A)

condenser lens elements. Instead, a brass shim is interposed between the two condenser lens elements.

(2) **RETICLE** (15, figure 6).—The reticle in instruments of this group has an integrally-tinted red pattern.

(3) **FILTER HOUSING** (1, figure 6).—The filter housing in instruments of this group is machined to accommodate the ball bearing fitted on the shaft of the control handle.

(4) **ELECTRICAL CONNECTION**.—A Breeze two-pin receptacle is provided with all instruments of this group.

(5) **LINE-OF-SIGHT CONTROL HANDLE** (3, figure 6).—The bushing pressed into the handle of instruments described in this section, paragraph 2. b., to provide smooth surfacing for the tapered center, is eliminated in control handles of these instruments. The control handle is fitted on a shaft which turns in a ball bearing pressed into the filter housing.

(6) **GYRO ASSEMBLY**. (See figure 6.)—The Pioneer type AN-5 gyro installed in instruments of this group differs from the Pioneer type AN-3 gyro as follows:

(a) **BEARING RETAINERS** (29).—Two bearing retainers replace the bushings of the ball bearing and bushing assemblies in the Pioneer type AN-3 gyro.

(b) **BRACKETS** (5).—Four clip brackets, held by screws which thread into the gyro frame cap, secure the reticle support and the erection system to the gyro. Removal of the clips makes it possible to lift the erection system from the gyro, without removing the drag cup, the rotor shaft nut, and the magnet, as in the Pioneer type AN-3 gyro.

d. **ARMY TYPE B-3 (PIONEER TYPES 2914-2A-B, 2916-2A-B, 2919-2A-A, and 2922-2A-A)**.—The assemblies and parts of these instruments are similar to the corresponding assemblies and parts of the instruments mentioned in this section, paragraph 2. c., with the following exception:

(1) **AZIMUTH DRIVE KNOB** (15, figure 7).—The azimuth drive has been redesigned to eliminate the thrust shaft. The spring-restrained azimuth drive knob is fitted to the worm shaft which slides in and out of a slot in the support bracket on the stationary housing. The worm is engaged by pulling out the azimuth drive knob, sliding the worm shaft in the slot toward the rotating tube, then releasing the knob. Disengagement results when the knob is pulled out, slid forward in the slot away from the rotating tube, and then released. One turn of the knob rotates the instrument in azimuth approximately 4 degrees.

e. **ARMY TYPE B-3 (PIONEER TYPES 2914-2A-C, 2916-2A-C, 2917-2A-B, 2919-2A-B, 2921-2A-A, 2923-2A-A, 2934-2D-A, 2935-2D-A), NAVY STOCK NO. R88-S-872-27 (PIONEER TYPES 2914-2A-C AND 2934-2D-A), NAVY STOCK NO. R88-S-872-51 (PIONEER TYPE 2919-2A-B), AND NAVY**

STOCK NO. R88-S-872-53 (PIONEER TYPES 2917-2A-B AND 2935-2D-A).—The assemblies and parts of these instruments are similar to the corresponding assemblies and parts of the instruments mentioned in this section, paragraph 2. d. with the following exceptions:

(1) **LOWER GYRO HOUSING** (20, figure 8).—A number of changes were made in the design of the lower gyro housing. The contact block assembly is positioned in a recess cut in the inner side. The gyro switch is installed in a recess cut in the opposite side of the housing. A groove is cut in a half circle across the upper part of the housing, and the gyro wire is cemented in the groove.

(2) **GYRO ASSEMBLY**. (See figure 8.)—Except for the following differences, the assemblies and parts of the Pioneer type AN-7 gyro are similar to the Pioneer type AN-5 gyro installed in instruments described in this section, paragraphs 2. c. and d.

(a) **ERECTION SYSTEM** (17).—The travel of the steel ball is limited by a roller subassembly and a ball stop. The ball stop, secured to the top plate, replaces the ball retainer bracket and the spacer in the Pioneer type AN-5 gyro erection system.

(b) **DRAG CUP**.—The drag cup is spun into the top plate and fitted with a drag-cup outer ring.

(c) **ROTOR ASSEMBLY** (24).—The lamination and resistance ring assembly is a shrink fit in the flywheel casting.

(d) **GYRO FRAME** (25).—The stator assembly is positioned on a shield secured to the floor of the frame by means of four rivets.

(3) **ELECTRICAL CONNECTIONS**.—On Pioneer types 2934-2D-A and 2935-2D-A, the electrical connector receptacle on the lower gyro housing is a standard AN disconnect plug receptacle. On all other Pioneer types described in this paragraph, the Breeze two-pin receptacle is used.

f. **TYPE AN5763 (PIONEER TYPES 2924-2A-A, 2926-2A-A, 2928-2A-A, 2929-2A-A, 2936-2D-A, 2938-2E-A, 2939-2E-A, 2940-2E-A, 2941-2E-A, 2944-2E-A, 2948-2E-A, 2949-2E-A-27, 2949-2E-A-33, 2949-2E-A-48 and 2949-2E-A-53)**.—The assemblies and parts of these instruments are similar to the corresponding assemblies and parts of the instruments mentioned in this section, paragraph 2. e., with the following exceptions:

(1) **GYRO PRISM** (15, figure 9).—The gyro prism is held in the prism holder by additional retainers which make it unnecessary to cement the corners of the prism in the holder as formerly.

(2) **INDEX PRISM** (2, figure 7).—A redesign of the holder and retainers eliminates the need for cementing the prism in the holder.

(3) **REFLECTING PRISM** (3, figure 7).—A redesign of the prism holder and retainers eliminates the need for cementing the reflecting prism in its holder.

(4) LOWER GYRO HOUSING (31, figure 9).

—Installation of the Pioneer type AN-20 gyro in instruments described in this paragraph requires the drilling of four tapped holes at the side of the housing to hold the transformer housing assembly. An additional hole is drilled in the housing for inserting the

transformer wire.

(5) TRANSFORMER HOUSING ASSEMBLY (33, figure 9).—This assembly contains a power transformer, a transformer cover, and a push-button switch. The assembly is mounted on the side of the lower gyro housing.

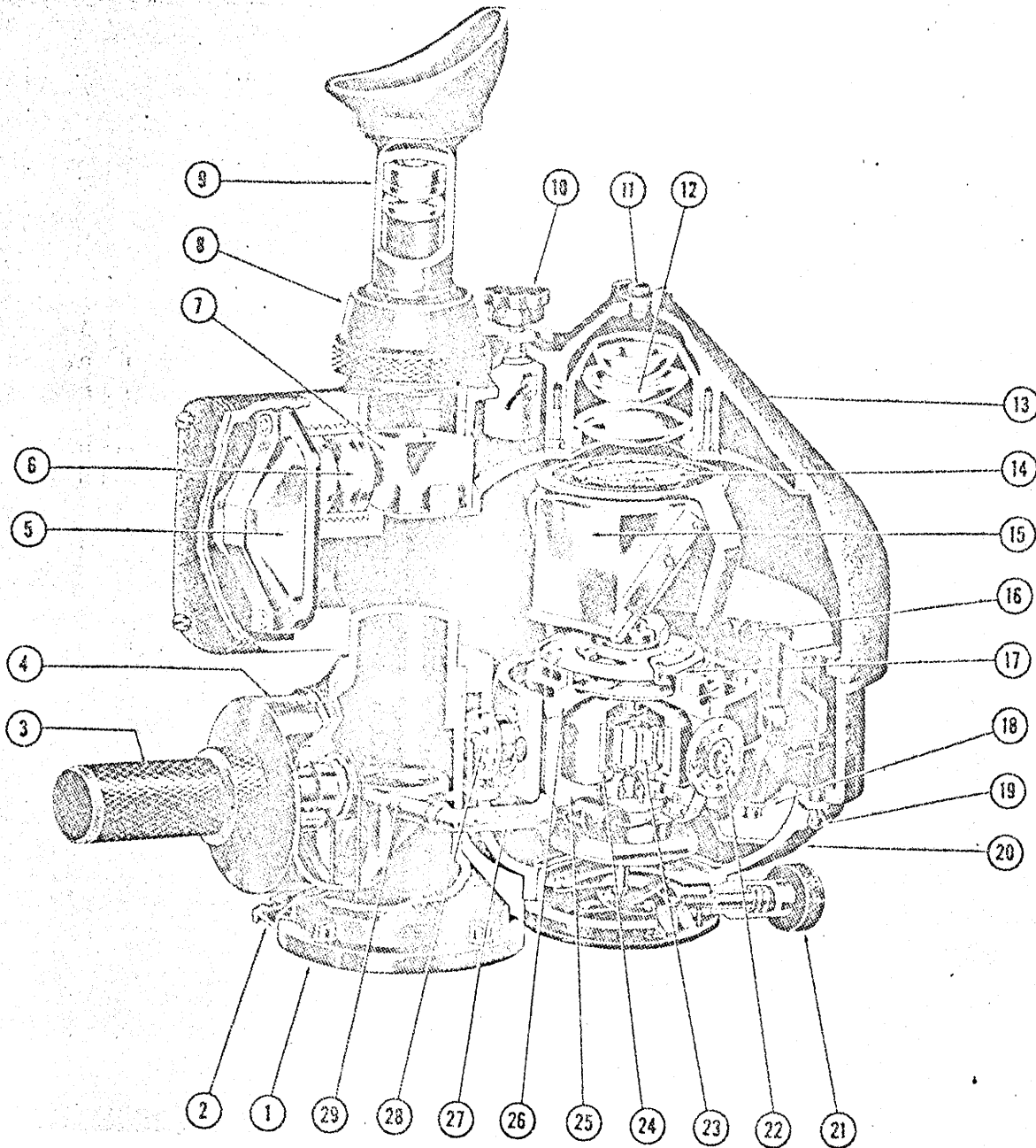

Filter housing
Index pointer
Line-of-sight control handle
Line-of-sight dial
Reticle lens reflector prism assembly
Gyro lens assembly,
Cube and pad assembly

8 Ocular housing holder
9 1X eyepiece assembly
10 Rheostat knob
11 Three-volt lamp assembly
12 Condenser lens assembly
13 Upper gyro housing
14 Reticle

15 Gyro prism
16 Case contact assembly
17 Erection system assembly
18 Socket
19 Switch
20 Lower gyro housing
21 Caging knob

22 Gyro pivot
23 Stator assembly
24 Rotor assembly
25 Gyro frame
26 Gyro frame cap
27 Filter handle
28 Gimbal ring pivot
29 Filter assembly

Figure 8—Three Quarter Cutaway View—Eyepiece End—Army Type B-3 (Pioneer Types 2914-2A-C, 2916-2A-C, 2917-2A-B, 2919-2A-B, 2921-2A-A, 2923-2A-A, 2934-2D-A, and 2935-2D-A), Navy Stock No. R88-S-872-27 (Pioneer Types 2914-2A-C and 2934-2D-A), Navy Stock No. R88-S-872-51 (Pioneer Type 2919-2A-B), and Navy Stock No. R88-S-872-53 (Pioneer Types 2917-2A-B and 2935-2D-A)

(6) **PUSH-BUTTON SWITCH** (32, figure 9).—When the push button is depressed, the transformer momentarily impresses 220 volts into the electrical circuit to start the gyro rotor.

(7) **GYRO ASSEMBLY.** (See figure 9).—The Pioneer type AN-20 gyro assembly differs from the Pioneer type AN-7 gyro assembly as follows:

(a) **ERECTION SYSTEM** (16).—The erection system assembly is a complete new design and consists of the following principal parts: erection bracket and bearing plate assembly, erection system counterweight, pawl assembly, and the ratchet and gear assembly. Small ball-bearing units are used in place of the pivot jewels. The erection system assem-

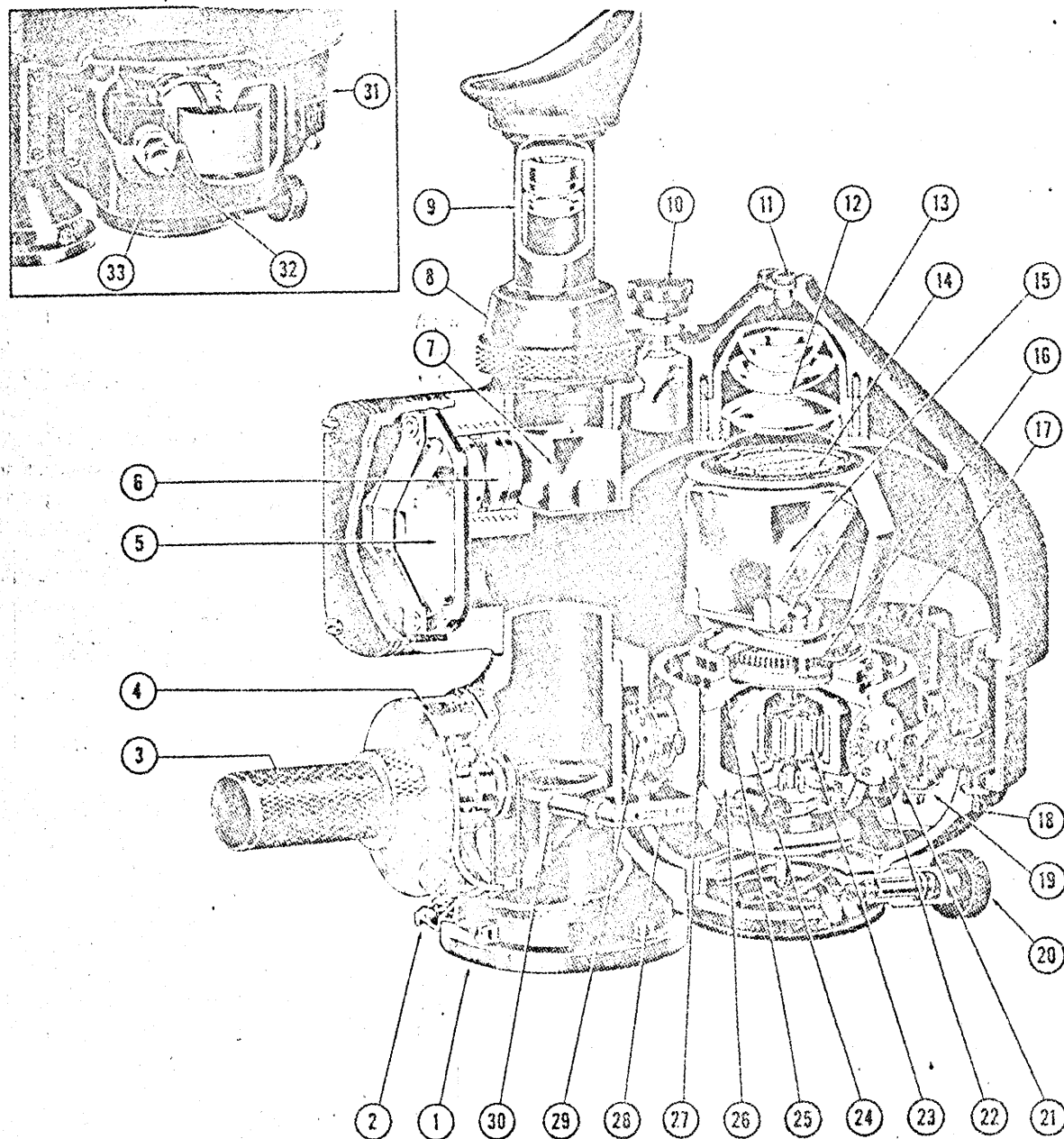

1 Filter housing
2 Index pointer
3 Line-of-sight control handle
4 Line-of-sight dial
5 Reticle lens reflector prism assembly
6 Gyro lens assembly
7 Cube and pad assembly
8 Ocular housing holder

9 1X power eyepiece assembly
10 Rheostat knob
11 Three-volt lamp assembly
12 Condenser lens assembly
13 Upper gyro housing
14 Reticle
15 Gyro prism
16 Erection system assembly

17 Case contact assembly
18 Gyro switch
19 Socket
20 Caging knob
21 Gyro pivot
22 Dust shield
23 Stator assembly
24 Rotor assembly
25 Gyro frame cap

26 Gyro frame
27 Gimbal ring
28 Filter handle
29 Gimbal ring pivot
30 Filter assembly
31 Lower gyro housing
32 Push button switch
33 Transformer housing assembly

Figure 9—Three-Quarter Cutaway View—Eyepiece End—Type AN5763 (Pioneer Types 2924-2A-A, 2926-2A-A, 2928-2A-A, 2929-2A-A, 2936-2D-A, 2938-2E-A, 2939-2E-A, 2940-2E-A, 2941-2E-A, 2944-2E-A, 2948-2E-A, 2949-2E-A-27, 2949-2E-A-33, and 2949-2E-A-53)

bly, in rotating on the ball track, is guided by the pinion of the ratchet and gear assembly which engages a gear, fixed to the gyro cap. This gear is used in place of the top plate and gasket. The erection system is held against the steel ball by means of a hairpin spring and a spring shield which fit around the collar of the gear. No brackets are required to prevent the steel ball from falling out of place.

(b) ROTOR ASSEMBLY (24).—The magnet is placed inside the open drag cup of the erection system, after the erection system is attached to the gyro. The magnet is attached to the rotor shaft by

means of a magnet retainer, which is held tightly by a pin. The magnet retainer has an end-clip which fits into a small surface hole in the magnet, so that the magnet can be replaced on the rotor shaft in the same relative position. The magnet requires no adapter or stop nut to hold it in place.

(c) STATOR AND FRAME ASSEMBLY (23).—The stator frame has no shield between the stator assembly and the bottom of the gyro frame.

(d)

Deleted in revision dated

SECTION III INSTALLATION

I. GENERAL.

a. The site chosen for the location of the gyro stabilized drift meter must be free of obstruction from other equipment in the airplane, so that the instrument may be rotated on its vertical axis through 360 degrees of arc without interference.

b. The drift meter is attached in a vertical position to the aircraft structure or supporting fixture by means of the mounting flange on the stationary housing. The flange is provided with holes for bolts to fasten the instrument in position.

c. It is important that the instrument be supported in the airplane at a height convenient for taking sights. In addition, sufficient headroom must be provided so that the navigator may have ready access to the instrument and may look directly down into it.

d. The objective end of the drift meter must project far enough beneath the fuselage to assure unrestricted vision of the horizon. The horizontal field of view must not be blocked by structural or other parts of the airplane.

e. In order to meet the requirements of various installations, instruments have been manufactured with tubes of various lengths, as measured from the bottom of the mounting flange. Consult table II, section II, for drift meter tube-length variations and corresponding type-number designations.

f. It is possible, also, to change the tube length of a particular instrument by removing the outer sleeve and the index prism adjusting rod and replacing them with an outer sleeve and an index prism adjusting rod of the desired length. However, these changes must be made only at an overhaul depot.

2. INSTALLATION PROCEDURE.

a. MOUNTING. (See figures 10, 11, and 12.)

(1) With the airplane positioned in normal level flight attitude, cut a hole in the floor of the fuselage at the site selected for placement of the drift meter.

CAUTION

Do not mount the drift meter where it will be used by personnel as a means of steadying themselves when walking back and forth in the aircraft. Personnel should be warned not to grab the head of the instrument when passing it. This practice can result in damage to the gyro.

(2) The hole in the floor of the fuselage should be approximately $\frac{3}{4}$ inch larger than the diameter of the drift meter tube. See figures 10, 11, or 12 for tube diameter dimensions, flange-mounting hole sizes and location, over-all length, etc. To protect the tube from the skin of the fuselage, fasten a rubber grommet or sponge rubber ring in the hole, before sliding the tube through the floor. **IN INSTALLATIONS WHERE THE TUBE LENGTH EXCEEDS 55 INCHES, USE A SECOND RUBBER GROMMET.**

CAUTION

DO NOT USE A FELT WRAPPER HELD BY WIRE TO PROTECT THE TUBE END EXTENDING THROUGH THE FUSELAGE FLOOR. After a period of operation, the felt is displaced or worn, causing damage to the tube and to the gyro mechanism.

(3) Provide a supporting bracket or structure for holding the instrument vertically at the desired height in the aircraft. Make proper allowance for the tube length necessary for obtaining clear, unobstructed vision of the ground below the airplane and of the horizon when sights are taken. A strong double metal support is suggested.

(4) To insulate the instrument against vibration, select four shock mounts in accordance with the weight of the instrument. *For shock mounting purposes only*, the weight of the drift meter can be cal-

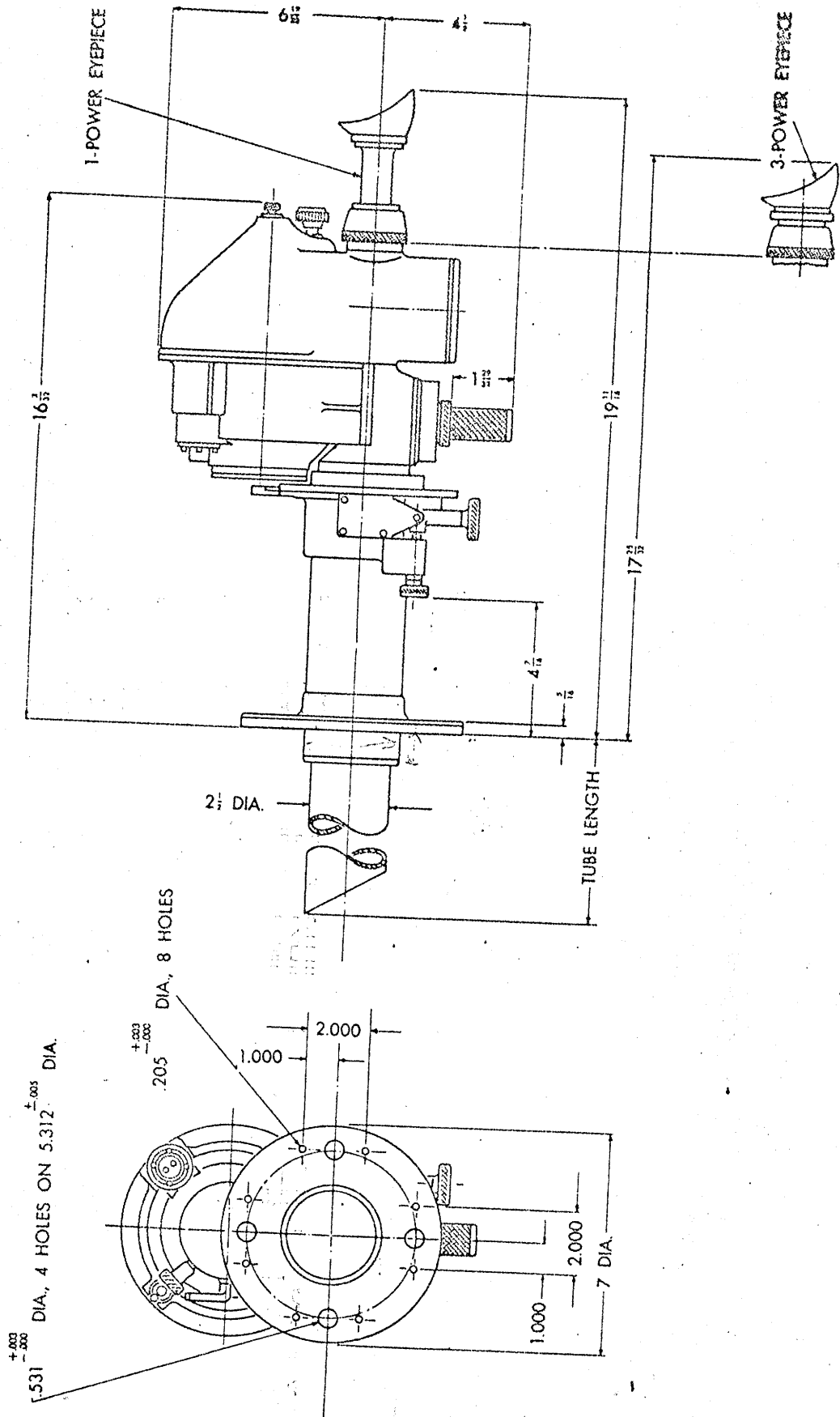

Figure 10—Outline Drawing—Army Type B-3 Gyro Stabilized Drift Meter with Thrust Shaft

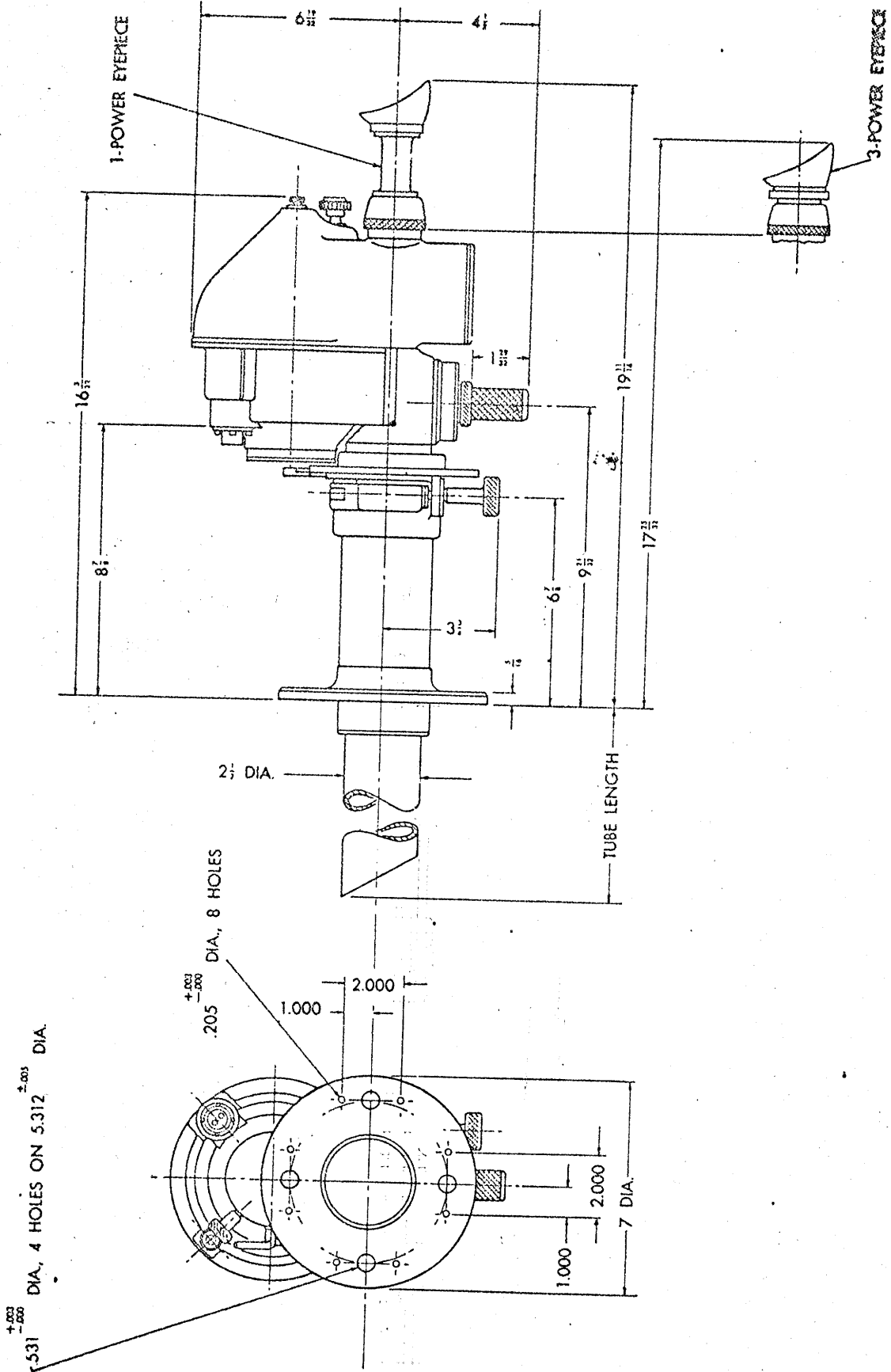
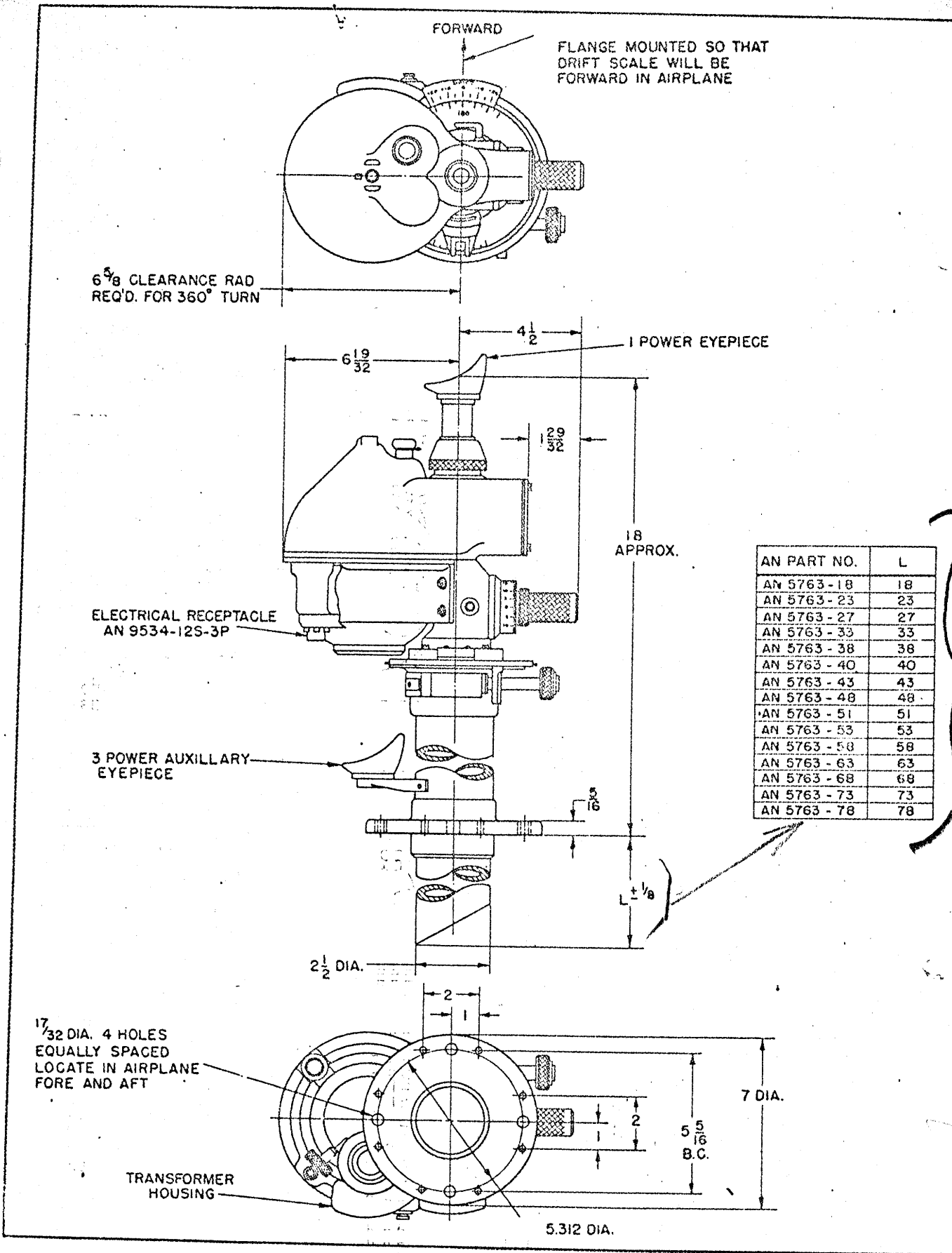

Figure 11—Outline Drawing—Gyro Stabilized Drift Meter with Redesigned Azimuth Drive



AN PART NO.	L
AN 5763 - 18	18
AN 5763 - 23	23
AN 5763 - 27	27
AN 5763 - 33	33
AN 5763 - 38	38
AN 5763 - 40	40
AN 5763 - 43	43
AN 5763 - 48	48
AN 5763 - 51	51
AN 5763 - 53	53
AN 5763 - 58	58
AN 5763 - 63	63
AN 5763 - 68	68
AN 5763 - 73	73
AN 5763 - 78	78

TUB
LEAK

Figure 12—Outline Drawing—Type AN5763 Drift Meter

culated by multiplying the tube length by 0.11 pound and then adding 18.8 pounds.

(5) Mount the drift meter so that its long axis is parallel to the vertical axis of the aircraft, with the zero mark of the drift scale forward. When installation is completed, an imaginary line through the zero graduations of the drift and azimuth scales must parallel the fore-and-aft axis of the aircraft.

(6) Bolt the mounting flange of the drift meter to the supporting structure.

b. RETICLE AND INDEX POINTER ALIGNMENT.

(1) The grid lines of the reticle must be parallel to the longitudinal, or fore-and-aft axis of the airplane. When the reticle lines are so positioned, the index pointer should indicate zero on the drift scale.

(2) Alignment of the reticle lines and the index pointer may be made as follows:

(a) Place the airplane with the nose pointed toward a relatively unobstructed horizon (not toward a body of water). By means of plumb bobs attached below the center line of the aircraft, fore and aft, lay out a line on the ground. Determine the distance that the driftmeter is located to the right or left of the center line of the aircraft. Lay out a line parallel to the original line and the same distance from the original line as the driftmeter is from the center line of the aircraft. This line will be parallel to the fore and aft axis of the aircraft and pass directly under the driftmeter. Standing to the rear of this line, sight

on a distant object, such as a tree on the horizon, that is directly in line with the parallel line if extended.

(b) Rotate the drift meter, with the gyro caged, until the index pointer is near the 0-degree point of the azimuth scale. By means of the line-of-sight control handle and the azimuth drive or tangent screw knob, sight upon the distant object and bring in into the center of the reticle system. If necessary, loosen the two screws which hold the index pointer on the filter housing, and adjust the pointer until its reference mark is exactly opposite the 0-degree point of the drift scale. Then tighten the two screws and secure the pointer in place.

c. POWER REQUIREMENTS AND ELECTRICAL CONNECTIONS.

(1) Type AN5763 instruments require 45 volt-amperes of 110 volts, 400 cycles during the 1-minute period when the starting transformer button on the lower gyro housing is depressed. Under normal operating conditions, these drift meters, like all those covered in this handbook, require 9 volt-amperes at 110 volts, 400 cycles.

(2) On all Type AN5763 instruments, the electrical connector receptacle is a two-pin receptacle conforming to AN9534-12S-3P. The same receptacle is used on Pioneer types 2934-2D-A and 2935-2D-A. On Pioneer types 2902-2A-A and 2910-2A-A, the cable is connected at the lower gyro housing by means of a soldered two-wire electrical connector plug. All other drift meter types use the Breeze E1003-13-20 receptacle.

SECTION IV OPERATION

1. PRINCIPLES OF OPERATION.

a. GENERAL. (See figure 13.)

(1) The gyro stabilized drift meter is an optical navigation instrument by which sights are taken on ground objects from the airplane for the determination of drift, azimuth (bearing angle) of a fixed object, and data from which ground speed and wind velocity may be computed. The instrument is mounted vertically in the airplane with its objective end protruding through and beneath the fuselage floor. An imaginary line through the zero marks of the drift and azimuth scales parallels the fore-and-aft axis of the aircraft. Before drift or azimuth sights are taken, the grid lines of the reticle are also aligned with the fore-and-aft axis of the plane and the index pointer indicates zero degrees on the drift scale. Both drift and azimuth scales remain in a fixed position and do not rotate with the instrument when observations are made. The line-of-sight scale and handle, by which the rotatable index prism is controlled, is used to measure vertical angles between a fixed ground object and the imaginary perpendicular line of sight extending from the drift meter to the earth beneath the plane.

(2) An electrically driven gyroscope is mounted in the housing at the eyepiece end of the instrument. The spinning gyro holds the reticle, which is attached above it, in a horizontal position so that when the grid lines and the sighted object are viewed simultaneously, no error is introduced as a result of motion (within 20 degrees from the vertical) of the surrounding portion of the instrument when the airplane rolls and pitches. The reticle image thus remains stable in relation to the earth's surface and does not move away from the image of the ground object even when the instrument is tilted from the vertical.

(3) Since the reticle does not receive light from the ground through the telescope tube, the three-volt lamp installed in the upper gyro housing provides the necessary illumination for the reticle optical system.

b. DRIFT METER OPTICS. (See figure 14.)

(1) Light from the observed ground object enters the drift meter telescope tube through the window and then through the rotating index prism on the main bracket. After reflection through the stationary reflecting prism to the objective lens, the light passes through the erector lenses in the middle of the tube to the beam-splitting cube in the upper gyro housing.

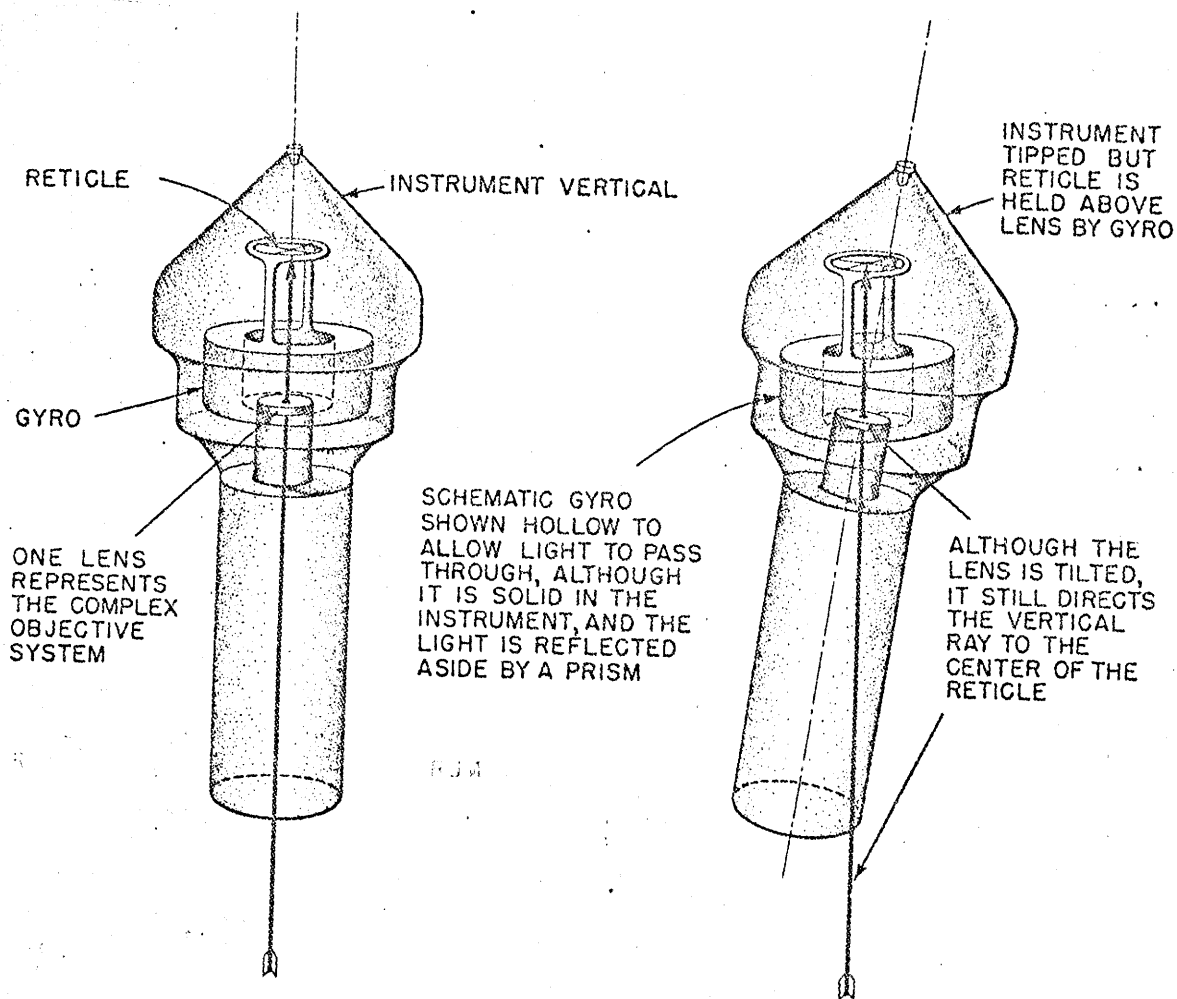

Figure 13—Schematic Diagram—Action of the Gyro in Gyro Stabilized Drift Meter

From there the light passes directly to the eyepiece.

(2) In the optical system of the gyro stabilized reticle, an image of the reticle lines is transmitted through a series of lenses and prisms and superimposed on the image of the sighted object as follows: Light from the three-volt lamp passes through the condenser lens assembly in the upper gyro housing and illuminates the grid lines of the reticle glass which is fastened to and positioned above the gyro. The light rays from the reticle are then deflected at a 90-degree angle by the gyro prism, and the light is directed to the 30-degree reflecting prism at the opposite side of the upper gyro housing. This prism bends the rays through 180 degrees and sends them through the gyro lens to the beam-splitting cube. The beam-splitting cube turns the reticle-image light rays through a 90-degree angle into the eyepiece. Thus, the images of the ground object and the reticle grid lines now travel the same path through the eyepiece, and are seen in coincidence and at the same instant.

(3) The drift meter has a true field of 25 degrees visible through the one-power (1X) eyepiece. With the one-power eyepiece, the ground object is the

same apparent size as when seen with the unaided eye. For studying detail, the one-power eyepiece may be replaced with the three-power (3X) eyepiece which is held in the spare eyepiece holder on the side of the stationary housing. However, the three-power eyepiece narrows the field to approximately 11 degrees, partially excluding the reticle image.

c. DRIFT METER GYRO.

(See figures 15 and 16.)

(1) The gyro which stabilizes the grid-lined reticle is driven by a self-contained electric motor. The gyro motor is of the split-phase capacitor type. Power input to the motor is approximately 8 watts, supplied from a 110-volt, 400-cycle, single-phase source. The motor is self-starting and power is supplied to the motor without the use of brushes, by means of an arrangement of metal contact strips.

(2) The capacitor phase of the gyro motor is shifted with respect to the main phase by means of two condensers connected in parallel to each other and in series with the capacitor winding. The condensers displace the phase of the current flowing in the capacitor winding 90 electrical degrees. The windings of the

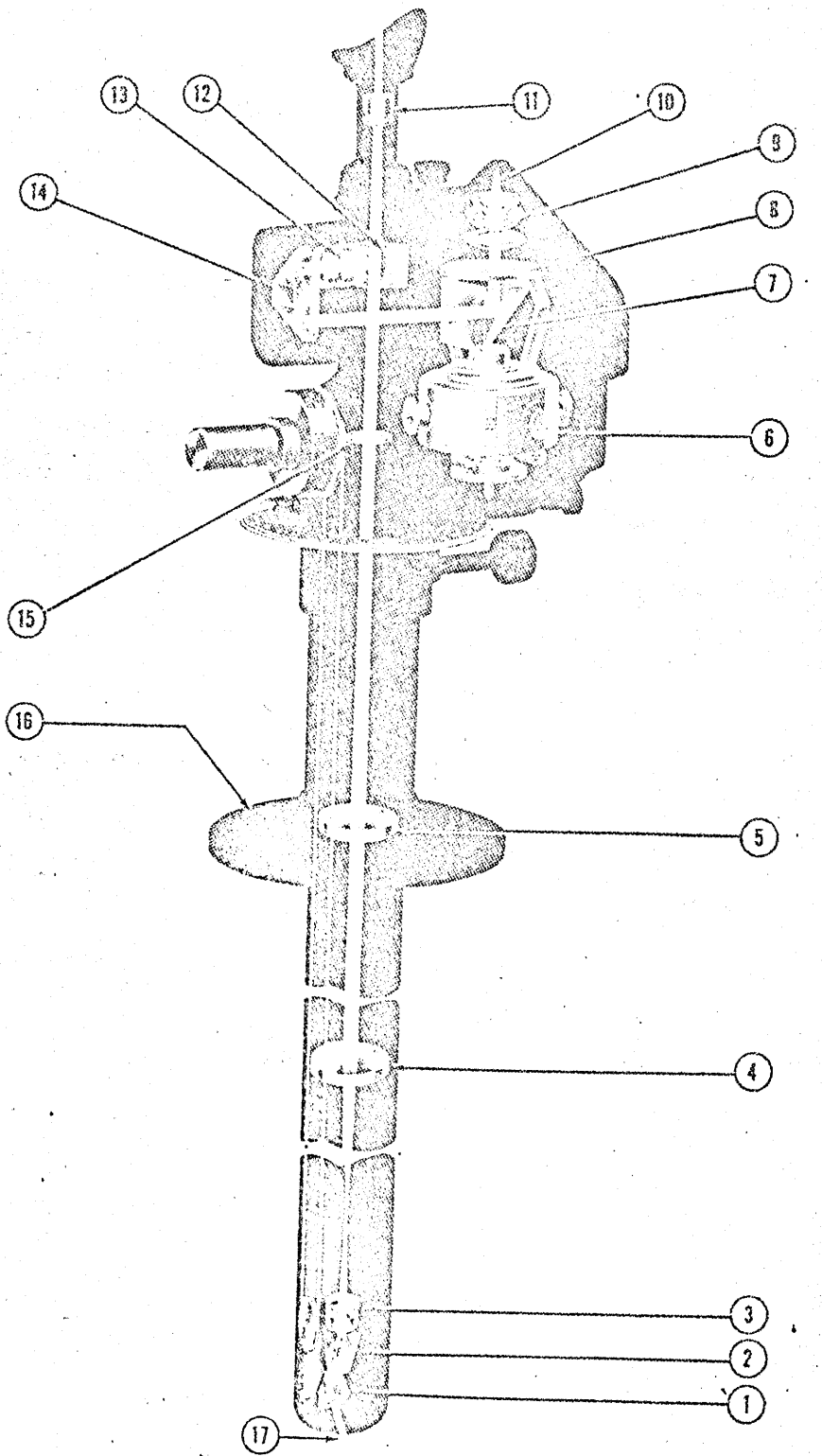

- | | | |
|-------------------------------|------------------------|----------------------------------|
| 1 Index prism | 7 Gyro prism | 13 Gyro lens |
| 2 Reflecting prism | 8 Reticle | 14 Reticle lens reflecting prism |
| 3 Eyepiece and objective lens | 9 Condenser lens | 15 Filter |
| 4 Lower achromat lens | 10 Three-volt lamp | 16 Stationary housing |
| 5 Upper achromat lens | 11 1X eyepiece lens | 17 Window |
| 6 Gyro | 12 Beam-splitting cube | |

Figure 14—Path of Images—Optical System—Gyro Stabilized Drift Meter

stator, when excited with this two-phase current, produce a rotating magnetic field which sets up eddy currents in the rotor.

(3) The rotating magnetic field, in combination with the eddy currents, causes the rotor to rotate inside the lower gyro housing. The normal operating speed of the rotor is approximately 10,600 rpm.

(4) The gyro is equipped with a mechanical erection system which overcomes the tendency of the spinning axis of the gyro to tilt from the vertical toward a horizontal plane. An erection system is necessary in order to cause the gyro to come quickly to vertical and, once there, to keep it in a vertical position. It contains a small steel ball which revolves in a circular horizontal track cut in the top of the gyro frame cap. The remainder of the erection mechanism, consisting of a ratchet and pawl assembly and a drag cup, is mounted above the track and is free to rotate.

(5) A small circular magnet attached to the rotor shaft of the gyro turns inside the drag cup. Eddy currents set up in the drag cup cause the erection system and the steel ball to turn at approximately 40 rpm when the gyro is up to speed. If the gyro axis tips toward the horizontal, the track of the rolling ball becomes tilted. The ball then rolls faster on the downhill side than on the uphill side. As a result, the weight of the ball acts on the uphill side for a longer time. This force causes the spinning axis of the gyro to return to a vertical plane. The ratchet and pawl is designed to regulate the speed of the mechanism, causing the gyro to erect in a substantially straight line.

d. DRIFT METER OPERATING CONTROLS.

(1) A rheostat, the knob and pointer of which is installed on the top of the upper gyro housing, is used to turn the three-volt lamp on and off and to control its brightness.

(2) A switch for starting and stopping the gyro is mounted on the side of the lower gyro housing.

(3) The caging knob located at the bottom of the lower gyro housing operates a mechanism which holds the gyro in a vertical position when it is not in use, or when it is tipped too far from the vertical during maneuvers.

(4) The slow-motion knob mounted on the stationary housing just beneath the azimuth scale, provides a means of fine adjustment of rotation of the instrument. It operates by means of a worm-gear mechanism which may be disengaged for free rotation of the drift meter.

(5) The lever mounted on the filter housing controls a shade glass. By operation of the lever, the shade glass may be interposed in the optical system to reduce the intensity of light when the ground image is too bright.

(6) When pressed, the push button on the transformer housing momentarily provides 220-volt power to start the gyro.

2. OPERATION INSTRUCTIONS.

a. BEFORE TAKE-OFF.

(1) See that the window in the objective end of the instrument and the top lens of the eyepiece are clean. For cleaning purposes, use a clean cotton or linen cloth. To remove sand or grit, brush the surfaces lightly with a small, clean paint brush, or a loose fold of cloth. Do not attempt to clean any other glass surfaces in the instrument.

(2) To prevent possible breakage of the drift meter glass by stones, set the instrument at zero on the drift scale before take-off (or landing).

(3) Keep the gyro switch in the "OFF" position and the gyro caged. To cage the gyro, pull out the caging knob and move it as far as possible toward the caged position. Pull the knob out gently—heavy handling will strain the sagging mechanism.

b. IN FLIGHT.

(1) With the airplane in normal level flight, close the switch on the junction box to start the inverter.

(2) Switch on the gyro, and allow it to run for from 3 to 5 minutes before uncaging.

(3) Uncage the gyro by pulling out the caging knob and moving it to the uncaged position. Do not uncage the gyro when the gyro motor is stationary or running slowly, since the gyro and reticle moving freely in the housing may become damaged. If a turn is started while the gyro is uncaged, do not attempt to cage it during the turn. Wait until the turn is completed, then cage the gyro. To prevent damage to the gyro, it is advisable to cage it before the drift meter is tipped more than 15 degrees from the vertical. To bring the gyro back to vertical if it has been tipped more than 15 degrees in a flight maneuver, it is necessary to run through a "cage-uncage" cycle.

(4) Always cage the gyro before switching off power to the instrument and keep it caged when it is not in use.

(5) When sighting through the eyepiece, turn the rheostat knob to adjust the illumination of the reticle lines.

(6) By means of the ocular housing holder on the upper gyro housing, adjust the focus of the eyepiece until the reticle lines are sharp and clear.

(7) Upon completion of drift meter observations, cage the gyro. Turn the gyro switch off, and then switch off the power supply to the inverter at the junction box.

c. FLIGHT APPLICATIONS.

(1) DETERMINING DRIFT.

(a) With the airplane in normal level flight and the drift meter in proper operation with gyro uncaged, as previously described, set the line-of-sight dial on zero. Take a sight on an object below the airplane which passes through the center of the reticle. By rotating the azimuth drive knob and the line-of-sight

control handle, follow the object back as the airplane passes over it, simultaneously keeping it in the center of the reticle. Take drift-angle readings from the drift scale at intervals, until 50 degrees is reached on the line-of-sight dial, and record them. Best results are obtained if the plane is stable within a few degrees. It is not advisable to attempt readings if the aircraft rolls or pitches beyond 15 degrees.

(b) The drift angle may also be measured as follows: Set the line-of-sight dial on zero. With the drift meter in proper operation, rotate the drift meter in azimuth and sight through the eyepiece. The airplane should be in steady level flight, although some rolling or pitching is permissible. When the reticle lines are parallel to the apparent motion of ground objects beneath the plane, note the reading on the drift scale. (Either the central or any of the side lines may be followed.) When flying over terrain or water where no prominent objects are discernible, align the reticle with the general movement of the earth's surface, without attempting to select any one objective.

(c) For measuring drift at night or during passage over calm water, a smoke pot or flare may be used as a drift signal. In daylight, the smoke appears as a conical plume. Use the extreme point of the cone as the sighting object (to the rear of vertical) in finding the drift angle.

(2) TAKING RELATIVE BEARINGS.—To take terrestrial bearings in relation to the airplane's heading, operate the instrument in the same way as when measuring drift. Turn the line-of-sight control handle and rotate the drift meter, bringing the object to the center of the reticle by means of the azimuth drive knob. Read the reference line of the index pointer against the azimuth scale to find the bearing angle.

(3) DETERMINING GROUND SPEED.
(See figure 17.)

(a) Ground speed may be determined by dividing a given ground distance by the time required to travel over that distance. This distance can be measured during flight. Ground speed may be computed simply if the necessary line-of-sight angles are used and the altitude is known. Line-of-sight (trail sight) angles may be measured with the line-of-sight control handle of the drift meter. Altitude may be obtained from the altimeter.

(b) Place the drift meter in operation. Sight a ground object and focus either the one-power or three-power eyepiece on it. With the gyro uncaged, rotate the drift meter so that the reticle lines are approximately parallel to the apparent direction of motion of the ground. Hold the object at the intersection of the cross hairs by turning the line-of-sight control handle and the azimuth drive knob. When the 50-degree detent is reached, start a stop watch. When the 70.9-degree detent is felt, stop the watch and

record the lapse of time. To find the ground speed in knots substitute the appropriate values in the formula:

$$\frac{A \text{ (Altitude) in feet}}{T \text{ (Time) in seconds}}$$

(c) Ground speed may also be determined with the line-of-sight control handle at zero, using the two outer ground speed lines of the reticle. With a stop watch, record the time required for a sighted object to pass from one outer ground speed line of the reticle to the other. To find the ground speed, substitute the appropriate values in the formulas:

$$\frac{K \times A \text{ (Altitude) in feet}}{T \text{ (Time) in seconds}} = \text{Ground Speed in Knots}$$

Reticle Angle (Degrees)	Factor K (for Knots)	Reticle Angle (Degrees)	Factor K (for Knots)
16.9	0.176	15.3	0.159
16.8	0.175	15.2	0.158
16.7	0.174	15.1	0.157
16.6	0.173	15.0	0.156
16.5	0.172	14.9	0.155
16.4	0.171	14.8	0.154
16.3	0.170	14.7	0.153
16.2	0.169	14.6	0.152
16.1	0.1675	14.5	0.151
16.0	0.166	14.4	0.150
15.9	0.165	14.3	0.1485
15.8	0.164	14.2	0.147
15.7	0.163	14.1	0.146
15.6	0.162	14.0	0.145
15.5	0.161	13.9	0.144
15.4	0.160		

$$\frac{C \times A \text{ (Altitude) in feet}}{T \text{ (Time) in seconds}} = \text{Ground Speed in Miles Per Hour}$$

Reticle Angle (Degrees)	Factor C (for Miles)	Reticle Angle (Degrees)	Factor C (for Miles)
16.9	0.203	15.3	0.183
16.8	0.2015	15.2	0.182
16.7	0.200	15.1	0.181
16.6	0.199	15.0	0.180
16.5	0.198	14.9	0.178
16.4	0.197	14.8	0.177
16.3	0.196	14.7	0.176
16.2	0.195	14.6	0.175
16.1	0.193	14.5	0.174
16.0	0.191	14.4	0.173
15.9	0.190	14.3	0.171
15.8	0.189	14.2	0.169
15.7	0.188	14.1	0.168
15.6	0.187	14.0	0.167
15.5	0.185	13.9	0.166
15.4	0.184		

(d) The "Reticle Angle" referred to in the table above is angular separation of the two outer ground-speed lines on the reticle. This angle is obtained with the plane on the ground. Observe a small mark on the ground at an angle of about 30 degrees down from the horizon. Turn the line-of-sight control handle until the sighted mark is first on one ground-speed line, then on the other. The difference between the two readings on the line-of-sight dial is the reticle angle.

(4) DETERMINING WIND VELOCITY.

(a) Wind velocity may be determined by constructing a diagram of velocities and drift angles. Lay

FORMULA
 GROUND SPEED IN KNOTS = $\frac{\text{"A" IN FEET}}{\text{"T" IN SECONDS}}$

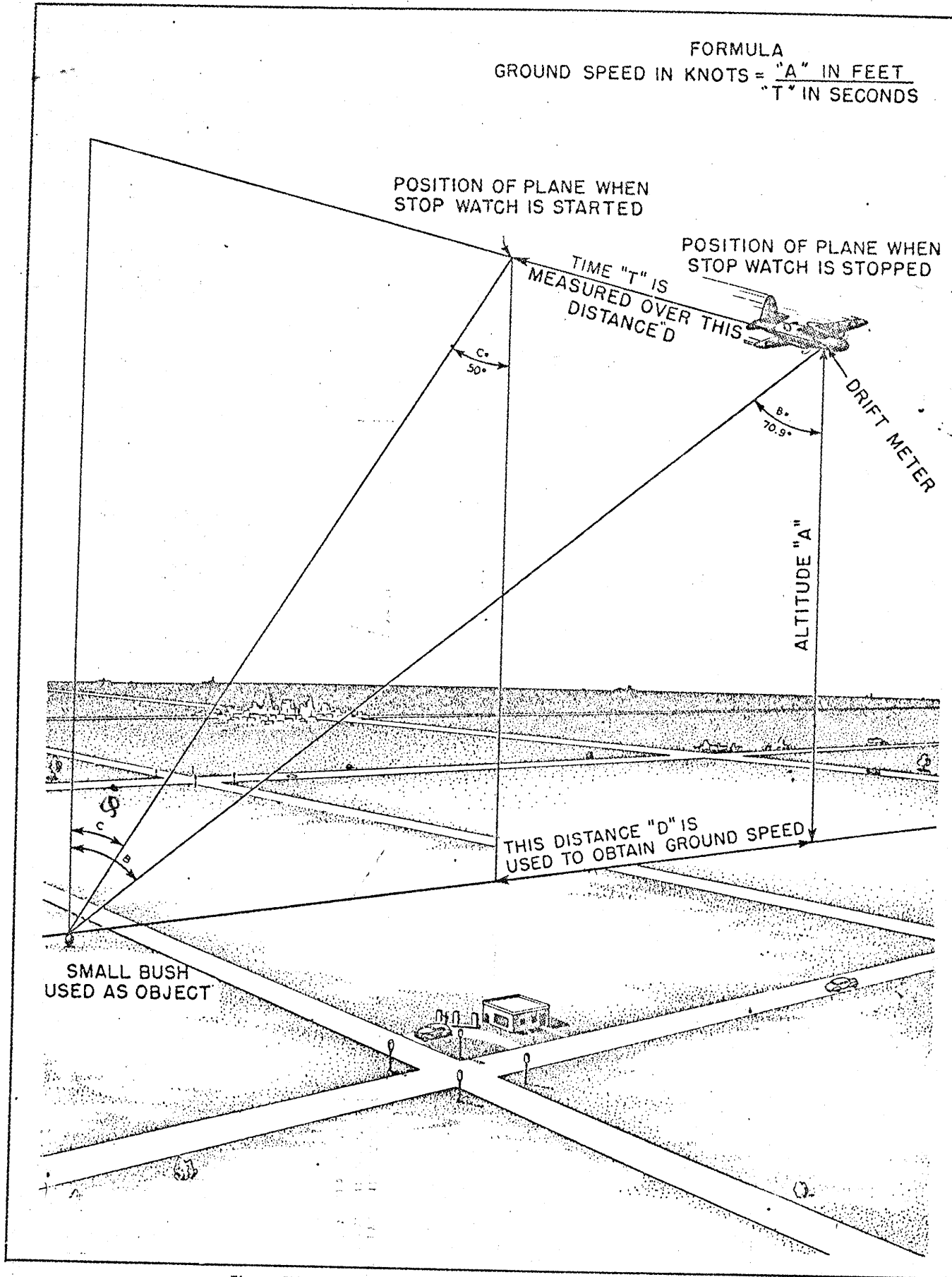

Figure 17—Diagram Showing Angles Used to Find Ground Speed

out the true air speed (indicated air speed corrected for altitude and temperature) along the heading and the ground speed along the track. The third side of the triangle will give wind speed and direction.

(b) With the drift meter in operation, set the line-of-sight dial at zero. Focus the one-power eyepiece sharply and sight on a selected ground object. Use the line-of-sight control handle and the azimuth drive knob to keep the image of the object at the center of the reticle. At frequent intervals, record the drift angle and direction (left or right of course). Discontinue drift measurements when the 50-degree mark on the

line-of-sight dial is neared. When the 50-degree detent is felt, start a stop watch, keeping the image in the center of the reticle. When the 70.9-degree detent is felt, stop the watch. Record the time interval. After computing ground speed, lay out the triangle of velocities as described in the preceding paragraph.

(c) Knowing his drift and ground speed at all times, the navigator can readily and accurately plot his position, his ETA (estimated time of arrival at destination), and take the proper steps to make good his intended course.

SECTION V

SERVICE INSPECTION, MAINTENANCE, AND LUBRICATION

1. SERVICE TOOLS REQUIRED.

No special service tools are required to perform the work described in this section.

2. SERVICE INSPECTION.

Note

Inspection periods established for AAF and Navy service organizations are not identical. For that reason, inspection periods specified in this section in terms of hours consist of two figures, i.e.: "25-30 Hour Inspection"; the first figure of which indicates the AAF periods, and the second figure of which indicates the comparable Navy period. Inasmuch as the Navy inspection periods do not exceed 120 hours, all inspections of longer duration shall be considered as the 2nd, 3rd, 5th, etc., 120 hour inspection.

Daily

Inspect the eyepiece lenses and the index prism window, and if necessary, clean these parts with alcohol and optical tissue.

50-60 Hour Inspection

Inspect the instrument for security of mounting, proper alignment in the airplane, freedom of operation, and for broken or damaged external parts. Check the operation of the lighting system in the upper gyro housing.

3. MAINTENANCE.

a. OPTICAL SYSTEM.

(1) Normal line maintenance should be limited to tightening of screws, cleaning the index prism window and the eyepiece lenses, and replacing the bulb in the three-volt lamp assembly, if it is defective.

(2) If the lenses and prisms inside the instrument must be cleaned, forward the instrument to the overhaul depot.

CAUTION

Do not overhaul or repair the optical system except at an overhaul depot equipped with adequate test equipment.

b. GYRO.—Once properly installed and operated the gyro should require no attention.

4. LUBRICATION.

a. OPTICAL SYSTEM.—Do not oil any part of the optical system. A number of parts of the system are lubricated with grease during overhaul only.

b. GYRO.—The parts of the gyro assembly are lubricated at time of overhaul. No lubrication of the parts of the gyro is performed except at the overhaul depot.

5. SERVICE TROUBLES AND REMEDIES.

Those few troubles which can be discovered and remedied during line maintenance are described below:

TROUBLE	PROBABLE CAUSE	REMEDY
INADEQUATE LIGHT ON RETICLE	Socket assembly set too high or low	Loosen setscrew in step on upper gyro housing and adjust position of socket assembly until maximum light is obtained.
SHIFTING IMAGE	Loose screws at either end of outer sleeve	Tighten all screws on outer sleeve.

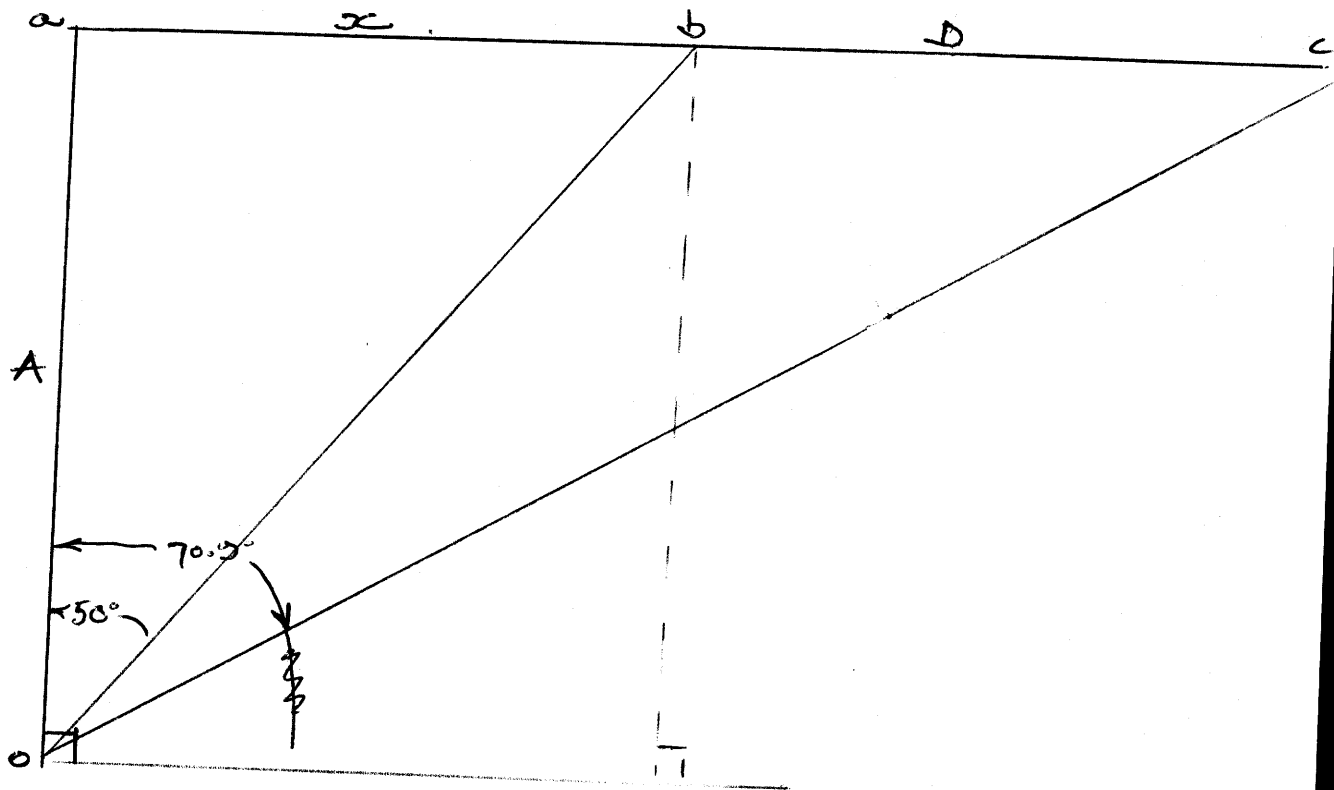

$$(G.S) = \text{GROUND SPEED (KNOTS)} = \frac{A \text{ (ft)}}{T \text{ (secs.)}}$$

Say G.S = 120 k then formula $\Rightarrow T = \frac{10,000 \text{ ft}}{120 \text{ k}}$
and $T = 83.3 \text{ sec.}$

$$\Delta oab, \overline{ab} = 10,000 \tan 50 = x \quad \text{EVEN}$$

$$\Delta oac, \overline{ac} = x + D = (x + D) \tan 70.54' = n$$

and, $x = 11918$

$n = 28878$

$D = n - x = 16,960 \text{ (ft)}$

120 knots = 140 m.p.h. $\times \frac{88}{224}$
= $7140 \times \frac{5280}{1893}$

$\text{ft/sec.} = 205.4 \text{ ft/sec.}$

$$v = \frac{s}{T} \Rightarrow T = \frac{s}{v} \Rightarrow T = \frac{16,960}{205.4} = 83 \text{ sec.}$$